

Panasonic®

■ This product is eligible for the AVCCAM
3 Year Warranty Repair Program. For
details, see page E-5 of vol.1.

Operating Instructions **Vol.2**

Memory Card Camera-Recorder

Model No. **AG-AF101E**

Volume **2**

Note that Operation Instructions Vol.2 describes advanced operations of the Memory Card Camera-Recorder. For instructions on basic operations of the Memory Card Camera-Recorder, refer to Operating Instructions Vol.1 (printed documents) contained in the supplied CD-ROM.

AVCCAM

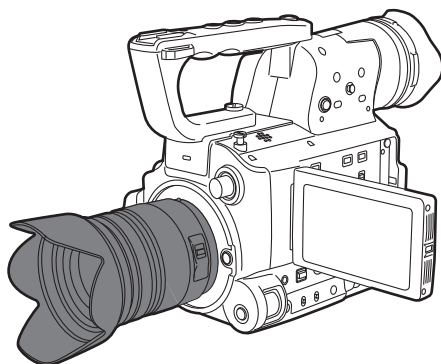

WVTM
MICRO

AVCHDTM

DOLBY
DIGITAL
STEREO CREATOR

HDMITM
HIGH DEFINITION MULTIMEDIA INTERFACE

SDTM
XC

Before operating this product, please read the instructions carefully and save this manual for future use.

Read this first!

Outline of operations
Please read before use
Operating precautions

Before use

Precaution for use
Accessories
Optional accessories

Description of parts

Description of parts

Preparation

Recharging the battery
Power sources
Adjusting the hand strap
Attaching/detaching the handle

Attaching/detaching the grip
The remote control
Turn on/off the camera
Tally lamp
Viewfinder
Setting the calendar

Shooting

Basic shooting operations
Basic operations of the camera

Menu

Using the setup menus
Setup menu structure

Reference

Specifications

Shooting

Shooting in progressive mode	4
Shooting techniques for different targets	5
Self-portrait shooting	5
Zebra pattern	5
Marker	6
Checking and displaying shooting status	6
PRE REC	6
Relay function.....	6
Variable frame rate (VFR).....	7
Shooting using the FUNCTION knob	10
Optical Image Stabilizer	11
Adding effects to images	11
Using the USER buttons	11
Backlight compensation	11
Color bars	11
Wave form monitor function.....	12
Adjusting the volume while shooting	12
Shot mark function	13
Index recording.....	13
LAST CLIP function	13
CAPTURE function.....	13

Adjusting the shutter speed	14
Using the SHUTR/F.RATE dial	14
Setting the SHUTTER	14
Setting the SYNCRO SCAN	14
FRAME RATE setting	14
Synchro scan.....	16
Switching Audio Input	17
Using the built-in microphone	17
Using an external microphone and audio equipment.....	17
Adjusting the recording level	18
Using scene files	19
Changing scene file settings	19
Saving scene files and other settings on SD Memory Cards	21
Clip metadata	22
Uploading the metadata (META DATA)	23
Selecting the USER CLIP NAME recording method	23
Using the Counter	24
Counter display	24
TC preset mode.....	24

Charging the built-in battery/	
Setting the time code	25
Recharging the built-in battery	25
Setting the time code	25
Specifying the time code (TC PRESET).....	25
Setting user information	27

Playback

Basic playback operations	28
Thumbnail screen	29
Basic thumbnail screen operations	29
Adding shot marks to clips	31
Select the card slot for playback	31
Playback settings (PLAY SETUP)	32
Set playback format (PB FORMAT).....	32
Repeat playback (REPEAT PLAY)	32
Resume playback (RESUME PLAY).....	33
Set skip method (SKIP MODE)	33
Thumbnail operations	34
Selecting the thumbnail display method	
(THUMBNAIL)	34
Deleting and protecting clips (OPERATION) ...	35
Copying clips (COPY)	36
Format card and check clip and	
card information (CARD FUNCTIONS)	37
Useful playback functions	39
Fast forward/rewind	39
Next/previous clip	39
Frame-by-frame playback	40
Adjust volume	40
Viewing images on a television	40
Checking the date and time.....	40

Editing

Connecting external units	41
Headphones	41
External microphone	41
Computer (non-linear editing/file transfer).....	42
TV/Monitor.....	42
Nonlinear editing	44

Displays

Screen displays	45
Regular displays	45
Main warning displays	48
Setting the DISPLAY items	50

Menu

Setup menu list	51
SCENE FILE screen.....	51
SW MODE screen	53
RECORDING SETUP screen.....	56
TC/UB SETUP screen	57
AV IN/OUT SETUP screen	58
DISPLAY SETUP screen	59
CARD FUNCTIONS screen	61
USER FILE screen	61
META DATA screen	62
OTHER FUNCTIONS screen	62
PLAY SETUP screen	64
THUMBNAIL screen	65
OPERATION screen.....	65

Reference

Before calling for service	66
Updating the firmware	
incorporated into the unit	70
Cleaning	71
Storage Precautions	72
How to handle data recorded on	
SD Memory Card	73

Shooting in progressive mode

Selecting 1080/30P or 1080/24P in the REC FORMAT option (Page 51) of the setting menu SCENE FILE screen enables shooting in progressive mode.

30P mode:

Shoot 30 frames a second in the progressive mode.

For output and recording, the 30-frame-per-second signal is converted to 60-field-per-second interlace.

This mode gives you high quality images.



24P mode:

Shoot 24 frames a second in the progressive mode.

The video signal will be recorded natively.

However, the external output signal is converted to a 2:3 format, 60 fps interlaced signal.

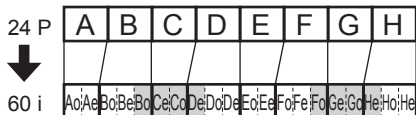

25P mode:

Shoots 25 frames a second in the progressive mode.

For output and recording of video signal, the 25-frame-per-second image is converted to 50-field-per-second interlace signal.

This mode gives high quality images.



Note the following when shooting in progressive mode.

- Set the shutter speed to 1/50 (OFF) for best results.
 - There may be a slight delay to the start of recording when you use the 24P mode because 4 frames are recorded at a time.
-

Shooting techniques for different targets

Self-portrait shooting

Images in the LCD monitor when it is turned 180° for self-portrait shooting may appear unusual. You can make them appear better by reversing left and right. Go to the setup menus, DISPLAY SETUP screen, SELF SHOOT, and select MIRROR. Shooting in mirror mode has no effect on what you actually shoot and record.

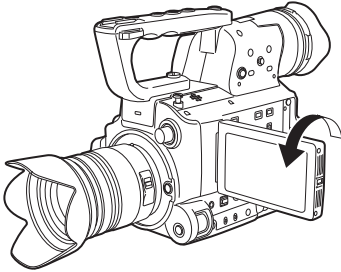

- Images played back by pressing the REC CHECK button cannot be inverted horizontally.
- Operation status displays during self-portrait recording
 - No display: Cannot record (no card, etc.)
 - : Recording in progress, during transition to the recording pause mode
 - ⏸: Recording paused (recording standby)
 - ⚠: Warning display
- Only part of the screen display appears. When [⚠] is displayed, turn the LCD monitor back in the direction of normal recording, and check what the message says.
- To confirm screen display information on the viewfinder, turn the LCD monitor to the normal shooting position.

Zebra pattern

Press the ZEBRA button in the CAM mode to show the zebra pattern or marker on the viewfinder and the LCD monitor so you can check the brightness of the subject.

Parts that may be whited out through over exposure are shown as a zebra pattern.

- Very bright
- Reflecting parts

ZEBRA button

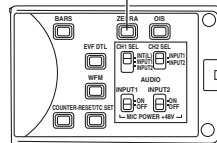

You can remove most overexposed parts by adjusting the iris and shutter speed in the manual mode to remove the areas with zebra patterns.

The display changes as follows each time you press the ZEBRA button.



In the setup menus, DISPLAY SETUP screen, ZEBRA DETECT1 and ZEBRA DETECT2, set the brightness for the zebra patterns. (Page 59)

If the ZEBRA DETECT2 item is set to OFF, ZEBRA2 will not be displayed even if the ZEBRA button is pressed.

The zebra pattern you have set appears as a percentage on the display for about 2 seconds.

The zebra pattern is displayed in the color bar as well.

Shooting techniques for different targets (continued)

Marker

If you press the ZEBRA button while the zebra pattern is being displayed, a marker appears in the center of the display (if you have set the setup menu, DISPLAY SETUP, MARKER to ON). The brightness of the areas near the screen center can be checked as a percentage (0% to 99%). "99%†" appears if the percentage is over 99.

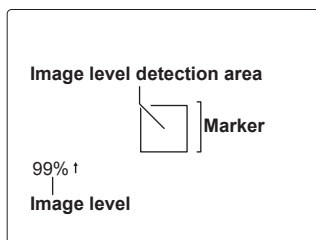

The normal display reappears if you press the ZEBRA button again.

Checking and displaying shooting status

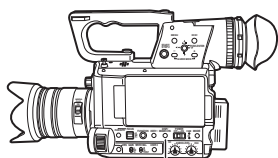

DISP/MODE CHK button

During recording or while recording is paused, information such as recording functions setting status and a list of functions allocated to the USER buttons can be displayed by keeping the DISP/MODE CHK button held down. Release the button to return to the normal display.

Pressing the DISP/MODE CHK button during recording or while recording is paused will remove all displays from the screen except for the operation status, frame display area etc., counter, marker, and safety zone display. Press the button again to return to the normal display. (Page 50) This setting will be maintained even if the camera's power is turned off by moving the POWER switch to the OFF position or if the operating mode is changed.

Pressing the DISP/MODE CHK button while the thumbnail screen is displayed in PB mode will display the properties of the selected clip. (Clips can be selected by moving the cursor with the Operation lever.)

PRE REC

Record video and audio from three seconds before the time of the operation to begin recording.

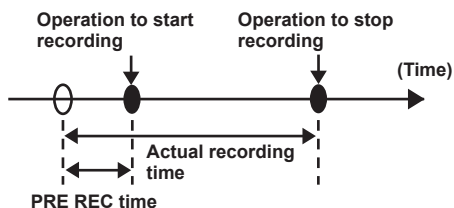

1 Set the PREREC MODE item on the RECORDING SETUP screen to ON.

PRE-REC will be displayed on the screen.

- When the TCG item on the TC/UB SETUP screen has been set to REC RUN, the setting will be automatically changed to FREE RUN.

2 Press the START/STOP button.

Video and audio from approximately 3 seconds previously will be recorded.

- Recording of the previous 3 seconds of video and audio may not be possible if recording is started immediately in the following cases.
 - Immediately after switching from PB mode to CAM mode
 - Immediately after turning power on
 - Immediately after changing to PREREC MODE item
- The thumbnail for clips recorded using the PREREC function will display the image from when the START/STOP button was pressed.

Relay function

When the remaining space on an SD card is insufficient during recording, recording can be continued using the other SD card slot.

Select ON in the RELAY REC item on the settings menu RECORDING SETUP screen.

- When the remaining space on an SD card is insufficient during recording, recording will automatically be continued using the SD card in the other slot.
- The relay function is not available when an SD card that cannot be recorded to is inserted in the SD card slot.
- The longest possible recording time with this camera is 12 hours. This cannot be extended even if the relay function is used.

Variable frame rate (VFR)

This camera can perform low speed (undercrank) and high speed (overcrank) recording without the need for a frame rate converter (the camera must be set to 1080_24p or 1080_30p).

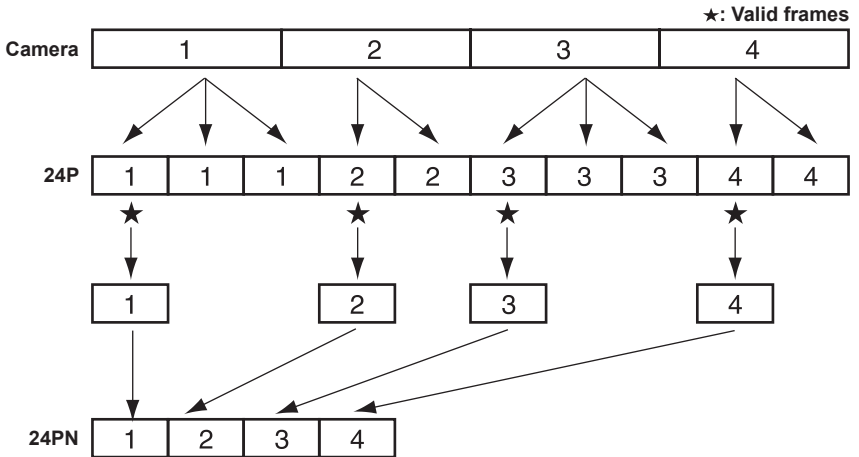

24P mode:

Shoots 24 frames a second in native mode. The images (shot at 24 frames a second) are recorded into 24 frames as the video signal.

- When VFR is set, the INTERVAL REC function, relay recording function, and PRE REC function are automatically set to OFF, and TCG is automatically set to REC RUN.
- The frame rate cannot be changed during recording.
- VFR shooting is only possible when shooting with REC FORMAT set to 1080_24p, 1080_30p or 1080_25p. VFR shooting does not work in the 720p mode.

The recording frame rate can be set to any one from the 20 frame rates given in the following table.

There is a slight difference between the displayed recording frame rate and the actual recording frame rate. Please refer to the table below.

When SYSTEM FREQ is set to 59.94 Hz

Indicated recording frame rate	60	54	48	44	40	36	34	32	30	28	27	26	25	24	22	21	20	18	15	12
Actual recording frame rate	59.94	53.74	47.54	43.96	39.96	35.97	33.88	31.73	29.97	27.83	27.25	25.97	24.98	23.98	21.98	20.75	19.98	17.63	14.99	11.99

When SYSTEM FREQ is set to 50 Hz

Indicated recording frame rate	50	48	45	42	37	34	32	30	28	27	26	25	24	23	22	21	20	18	15	12
Actual recording frame rate	50.00	48.08	45.45	41.67	36.76	34.09	31.82	30.00	27.78	26.79	26.04	25.00	24.00	23.08	22.06	20.83	20.00	17.86	15.00	12.50

Shooting techniques for different targets (continued)

Native recording

- 1** Select 1080/24P recording format from the REC FORMAT option (page 51) on the settings menu SCENE FILE screen.
 - 2** From the OPERATION TYPE option (page 51) on the settings menu SCENE FILE screen, select FILM CAM, and set the FRAME RATE (page 51) to an arbitrary recording frame rate.
 - 3** Press the START/STOP button
Start native recording in VFR mode.
- Although the audio is not recorded, the sound is output from the AUDIO OUT terminal, HDMI terminal, and SDI OUT terminal during setup and during recording.
 - During the VFR mode, the camera is set to manual focus mode.

Standard recording

- 1** Select 1080/30P recording format from the REC FORMAT option (page 51) on the settings menu SCENE FILE screen.
- 2** From the OPERATION TYPE option (page 51) on the settings menu SCENE FILE screen, select FILM CAM, and set the FRAME RATE (page 51) to an arbitrary recording frame rate.
- 3** Press the START/STOP button.
Start standard recording in VFR mode.
 - Although the audio is not recorded, the sound is output from the AUDIO OUT terminal, HDMI terminal, and SDI OUT terminal during setup and during recording.
 - During the VFR mode, the camera is set to manual focus mode.
 - 2:2 pull down recording will be applied for a recording frame rate of 30P.

Use of Variable Frame Rate (VFR)

Normal speed shooting for movie production

When producing videos for screening, a frame rate of 24fps as used in film projection is standard (x1). By using the settings below, playback with the same quality as the film projection is possible. Film like high quality video can be produced through 1080p progressive and CINELIKE Gamma.

Recording format (REC FORMAT)	Recording frame rate (FRAME RATE)
1080P/24P (native recording)	24 fps*

Normal speed shooting for commercial/drama production

When producing videos for display on television screen such as HDTV/SDTV broadcast, a frame rate of 30fps is standard (x1). By using the settings below, playback with the same quality as broadcast is possible. Commercials and music videos can be recorded at film-like high quality, and at a frame rate suitable for television broadcast.

Recording format (REC FORMAT)	Recording frame rate (FRAME RATE)
1080/30P (2:2 Pull down)	30 fps*
1080/25P	25 fps*

Undercrank shooting

This is a quick motion effect that can be applied to scenes showing the flow of clouds, people standing in the middle of crowds, and kung fu, etc. For example, a quick motion effect of x2 can be gained if the VFR recording frame rate is set to 12fps when recording with the 24P recording format that specifies the playback frame rate.

Recording format (REC FORMAT)	Recording frame rate (FRAME RATE)
1080/24P	Less than 22fps*
1080/30P	Less than 28fps*
1080/25P	Less than 24fps*

Overcrank shooting

This is a slow motion effect that can be applied to scenes such as car chases, action, climaxes, etc. For example, a slow motion effect of 1/2 can be gained if the VFR recording frame rate is set to 60fps when recording with the 30P recording format that specifies the playback frame rate. 1080P progressive movies produce smooth, high quality slow motion.

Recording format (REC FORMAT)	Recording frame rate (FRAME RATE)
1080/24P	Less than 25fps*
1080/30P	Less than 32fps*
1080/25P	Less than 26fps*

* The recording frame rate (FRAME RATE) can be set to one of 20 values. (page 14)

Shooting using the FUNCTION knob

The following types of recording can be carried out using the FUNCTION knob.

- Area auto focus function
Operates auto focus within an area frame selected using the FUNCTION knob.
- Area auto iris function
Automatically adjusts the iris value within an area frame selected using the FUNCTION knob. This function cannot be set when the FACE DETECT function has been set.
- Area luminance display
Displays an averaged luminance level within an area frame selected using the FUNCTION knob.

1 Select the function from the FUNCTION KNOB option (page 53) on the settings menu SW MODE screen.

FOCUS: Area focus function and area focus bar function (during MENU setting)

IRIS: Area iris function and area iris meter function (during MENU setting)

YGET: Area luminance display

FOCUS/IRIS:
Simultaneous operation of the area focus function and area iris function, simultaneous operation of the area focus bar function/area iris meter function (during MENU setting)

FOCUS/YGET:
Simultaneous operation of area focus function and area luminance display, simultaneous operation of area focus bar function (during MENU setting)

2 Press the FUNCTION knob.

- A white frame is displayed.
- There is no change in the operation of the camera other than the display of the frame.

3 Press the FUNCTION knob again.

- The white frame turns yellow.
- When the frame is yellow, the FUNCTION knob function set via the MENU operates in the area inside the frame.
- Pressing the FUNCTION knob once more returns the yellow frame to the white frame.
- Switching AUTO/MANUAL for FOCUS/IRIS is normally carried out in the same way.
- The central luminance function does not operate when the area luminance display is operating.
- If the FUNCTION knob is held down for more than 2 seconds, the frame disappears and the area function is switched off.

4 Move the FUNCTION knob up and down, and right and left.

- The white frame changes position. Move the frame to the area you wish to select.

-
- The area function does not operate during face detection.
 - The area function exits when the power switch is set to OFF or when the camera is switched to playback mode.
 - Auto focus and auto iris may not be available depending on lens used.
 - The area luminance, FOCUS BAR, and IRIS METER functions are available regardless of the lens used.
-



Optical Image Stabilizer

Use the Optical Image Stabilizer (OIS) to reduce the effects of camera shake when shooting by hand.

Press the OIS button to turn the function on and off.  appears on the viewfinder and the LCD monitor when this function is on. Turn the function off when using a tripod for more natural images.

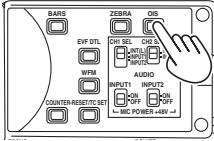

- For lenses that have an OIS button, only the lens button is active and the button on the camera is deactivated. Also, some lenses do not have an OIS function.
- This function will not be as effective when the vibration is severe or when tracking a moving subject.

Adding effects to images

Press the USER button you have allocated to the BLACKFADE or WHITEFADE feature to add fading effects to your images. The button's function is forcibly canceled during playback or REC CHECK and also when thumbnails are displayed.

BLACKFADE:

Press the button to fade out to black. Audio also fades out. Fade-in starts after fade-out, when the button is released.

WHITEFADE:

Press the button to fade out to white. Audio also fades out. Fade-in starts after fade-out, when the button is released.

Using the USER buttons

You can allocate one of thirteen features to each of the three USER buttons.

Use these buttons to change shooting settings quickly or add effects to the images you are shooting.

The following features are allocated to the buttons at the time of shipping.

USER1: FA

USER2: ATW LOCK

USER3: REC CHECK

For details, see the setup menus, SW MODE screen, USER1 SW to USER3 SW. (Page 55)

If you press a USER button to which one of the functions has been assigned, and then turn OFF the power or change the mode during operation of the USER button function, the effect added to the image will not be retained.

Backlight compensation

Press the USER button you have allocated to the BACKLIGHT feature when shooting subjects lit from the back.

BACK appears on the screen.

Backlight compensation adjusts the iris so the subject doesn't come out dark.

Press the same USER button to turn the feature off. (In the manual iris mode, the iris status is retained at the corresponding point even when backlight compensation is canceled.)

- The backlight compensation function does not operate with lenses in which AUTO IRIS is not functioning.

Color bars

Press the BARS button in the CAM mode to output a color bar screen to a television or monitor so you can adjust them. Press the button again to turn the feature off.

- While the color bar is displayed, a test tone of 1 kHz will be output from the headphone terminal or the AUDIO OUT terminal. There will be no speaker output.
- The color bar can be recorded by pressing the START/STOP button.
- The color bar display is canceled when the power is turned off.

Wave form monitor function

An image wave form can be displayed on the LCD monitor by pressing the WFM button while in CAM mode.

Press the button again to return to the normal display.

- Switching the wave form display, vector display, and wave/vector display is possible from the WFM item (page 55) in the SW MODE screen of the settings menu.
- Wave forms will not be displayed in the viewfinder.
- Wave forms cannot be recorded.
- While wave forms are displayed, use the viewfinder as well because a part of the recording screen and screen display will be hidden by wave forms.

Adjusting the volume while shooting

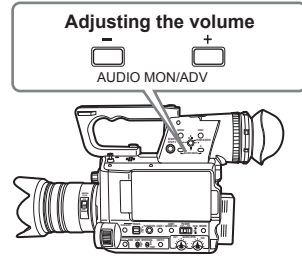

If you are monitoring the sound through headphones while shooting, you can adjust the volume with the AUDIO MON/ADV buttons.

- To adjust the recording level. (Page 18)
- Volume adjustments will be memorized if the power is turned off by moving the POWER switch to the OFF position.

Shot mark function

The marks attached to the thumbnails of clips are called shot marks. On the thumbnail screen monitor you can select only those clips with a shot mark and display them or play them back. During recording, when you press the USER button to which the SHOT MARK function has been allocated, MARK ON appears in the LCD monitor or the viewfinder, and a shot mark is set for the thumbnail of the clip being recorded. If you press the button again, the shot mark is released. You can also set or release the shot marks by performing the thumbnail operations for clips. (Page 31)

However, note that you cannot set or release shot marks during playback.

- INVALID appears when you cannot set or release shot marks.

Index recording

This function allows you to add an index at a certain point of a clip during the recording or playback.

Press the USER button allocated to the INDEX function during recording to record an index signal at this point of the clip. (Pages 11, 55)

Indexes may also be added during playback, and it is also possible to select only clips with indexes for display or playback. (Pages 34, 35)

-
- Up to 100 indexes can be recorded for one clip.
 - When the number of indexes exceeds 100, INVALID is displayed, and no further indexes can be added even when the steps for adding indexes are taken.
 - When repeatedly adding indexes, leave a gap of at least one second between adding one index and the next. If indexes are added with a gap of less than one second between them, only the first operation will be valid.
-

LAST CLIP function

The most recently recorded clip can be deleted at the touch of a button by allocating the LAST CLIP function to any of the USER 1 - 3 buttons.

Press the USER button allocated for the LAST CLIP function to display YES/NO on the screen. Select YES to delete the most recently recorded clip.

- Select NO not to delete the clip.
- If the camera has been switched to PB mode or the recording format has been changed since recording was completed, clips cannot be deleted even if the button is pressed. Clips also cannot be deleted if the power has been switched off and back on again.
- Clips cannot be deleted even if the button is pressed if the memory card has been removed and reinserted since recording was completed.

CAPTURE function

If the CAPTURE feature is assigned to any of the USER 1 - 3 buttons, still images can be shot.

-
- The number of recorded pixels and quality of the still images cannot be changed.
 - This function does not operate when a movie is being recorded, or when the PRE REC mode is in use.
 - The SD memory card used for recording is the same as that used for video recording.
-

Adjusting the shutter speed

Using the SHUTR/F.RATE dial

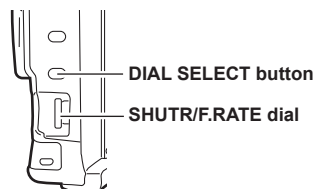

Press the DIAL SELECT button.

- The role of the SHUTR/F.RATE dial changes in the following order.
SHUTTER → SYNCRO SCAN → FRAME RATE
→ DIAL LOCK → SHUTTER →
- SYNCRO SCAN can be selected when the SHUTTER is set to SYNCRO SCAN. FRAME RATE can be selected in the FILM CAM mode when the REC FORMAT is 1080/24P, 30P, and 25P.

To prevent incorrect operation, it is recommended that you selecting DIAL LOCK using the DIAL SELECT button after setting.

Setting the SHUTTER

- 1 Select the SHUTTER function with the DIAL SELECT button.**
- 2 Press the SHUTR/F.RATE dial.**
 - The shutter will turn ON/OFF.
 - The shutter speed is changed in the order shown on the following page by turning the SHUTR/F.RATE dial when the shutter is ON.

- Remember that the faster the shutter speed, the lower the sensitivity.
- Focusing on the subject would take longer if the shutter speed is reduced. It is therefore recommended that the unit be secured to a tripod, etc. during shooting.
- Under the lighting of electric discharge tubes such as fluorescent lamps, horizontal bands may appear on the screen. Adjusting the shutter speed may improve this condition.
- A subject that quickly crosses the camera may appear distorted when shot. This is caused due to the signal reading system of the imaging element (MOS sensor), and is not a defect.
- At slow shutter speeds (1/2 to 1/15), white, red, green, or blue dots may appear on the screen. However, this is not a defect.

Setting the SYNCRO SCAN

- 1 Select SYNCRO SCAN from the SHUTTER settings.**
- 2 Select the SYNCRO SCAN function with the DIAL SELECT button.**
- 3 Turn the SHUTR/F.RATE dial.**
 - The SYNCRO SCAN shutter speed can be set.
 - The speed of change increases when turning the SHUTR/F.RATE while holding it down.
 - SYNCRO SCAN can also be set from the SYNCRO SCAN item in the SCENE FILE screen of MENU settings.

Setting format differs depending on the MENU-SCENE FILE-OPERATION TYPE.

FILM CAM: angle display (180.0d etc.)

VIDEO CAM: speed display (1/48.0 etc.)

FRAME RATE setting

- 1 Select the FRAME RATE function with the DIAL SELECT button.**
- 2 Press the SHUTR/F.RATE dial.**

The camera is in VFR mode.

 - The FRAME RATE can be set by turning the SHUTR/F.RATE dial.
 - FRAME RATE can also be set from the FRAME RATE item in the SCENE FILE screen of MENU settings.

- Before using the FRAME_RATE function, it is necessary for the MENU-SCENE FILE-OPERATION TYPE to be set to FILM CAM, and the MENU-SCENE FILE-REC FORMAT to be set to PH1080/24P or PH1080/30P (or PH1080/25P).
- The FRAME RATE function cannot be set when SDI 24PsF is set to ON in the AV IN/OUT SETUP screen of MENU settings.
- When the FRAME RATE function is set to ON, the camera is automatically set to manual focus.

When SYSTEM FREQ = 59.94Hz /OPERATION TYPE = FILM CAM

1080/60i, 720/60P	
Normal (OFF) 1/60	<p>SYNCRO SCAN ↔ 1/100 ↔ 1/120</p> <p>↓</p> <p>1/2000 ↔ 1/1000 ↔ 1/500 ↔ 1/250</p> <p>↑</p>
1080/30P, 720/30P	
Normal (OFF) 1/50	<p>SYNCRO SCAN ↔ 1/30 ↔ 1/60 ↔ 1/120</p> <p>↓</p> <p>1/2000 ↔ 1/1000 ↔ 1/500 ↔ 1/250</p> <p>↑</p>
1080/24P, 720/24P	
Normal (OFF) 1/50	<p>SYNCRO SCAN ↔ 1/24 ↔ 1/60 ↔ 1/120</p> <p>↓</p> <p>1/2000 ↔ 1/1000 ↔ 1/500 ↔ 1/250</p> <p>↑</p>

SYSTEM FREQ = 50Hz /OPERATION TYPE = FILM CAM

1080/50i, 720/50P	
Normal (OFF) 1/50	<p>SYNCRO SCAN ↔ 1/60 ↔ 1/120</p> <p>↓</p> <p>1/2000 ↔ 1/1000 ↔ 1/500 ↔ 1/250</p> <p>↑</p>
1080/25P, 720/25P	
Normal (OFF) 1/50	<p>SYNCRO SCAN ↔ 1/25 ↔ 1/60 ↔ 1/120</p> <p>↓</p> <p>1/2000 ↔ 1/1000 ↔ 1/500 ↔ 1/250</p> <p>↑</p>

SYSTEM FREQ = 59.94Hz /OPERATION TYPE = VIDEO CAM

1080/60i, 720/60P	
Normal (OFF) 1/60	<p>SYNCRO SCAN ↔ 1/2 ↔ 1/4 ↔ 1/8 ↔ 1/15 ↔ 1/30</p> <p>↓</p> <p>1/2000 ↔ 1/1000 ↔ 1/500 ↔ 1/250 ↔ 1/120 ↔ 1/100</p> <p>↑</p>
1080/30P, 720/30P	
Normal (OFF) 1/50	<p>SYNCRO SCAN ↔ 1/2 ↔ 1/4 ↔ 1/8 ↔ 1/15 ↔ 1/30</p> <p>↓</p> <p>1/2000 ↔ 1/1000 ↔ 1/500 ↔ 1/250 ↔ 1/120 ↔ 1/60</p> <p>↑</p>
1080/24P, 720/24P	
Normal (OFF) 1/50	<p>SYNCRO SCAN ↔ 1/2 ↔ 1/3 ↔ 1/6 ↔ 1/12 ↔ 1/24</p> <p>↓</p> <p>1/2000 ↔ 1/1000 ↔ 1/500 ↔ 1/250 ↔ 1/120 ↔ 1/60</p> <p>↑</p>

SYSTEM FREQ = 50Hz /OPERATION TYPE = VIDEO CAM

1080/50i, 1080/25P, 720/50P, 720/25P	
Normal (OFF) 1/50	<p>SYNCRO SCAN ↔ 1/2 ↔ 1/3 ↔ 1/6 ↔ 1/12 ↔ 1/25</p> <p>↓</p> <p>1/2000 ↔ 1/1000 ↔ 1/500 ↔ 1/250 ↔ 1/120 ↔ 1/60</p> <p>↑</p>

Synchro scan

The synchro scan shutter speed used when shooting screens such as a TV screen or computer monitor is set using the SHUTTR/F RATE dial (page 14) or the SYNCRO SCAN option on the settings menu SCENE FILE screen. (page 51)

- Adjust the shutter speed to match the frequency of the television or computer monitor to minimize the horizontal noise that appears when shooting such subjects.
- By switching to progressive mode you can also shoot PAL system television screens.
- If the set value of the SYNCRO SCAN item of settings menu is displayed in gray, it cannot be used with the current recording format. This function will only operate for preset values for each recording format, as listed below.

60i/60P mode: 1/60

30P mode: 1/30

You can change the progressive mode in the setup menu with REC FORMAT in the SCENE FILE screen. (Page 51)

Switching Audio Input

During shooting, you can record up to two channels of sound. You can also switch the input sound to be recorded on each of the channels to the built-in microphones, external microphones or audio equipment connected to camera.

CH1 SELECT switch

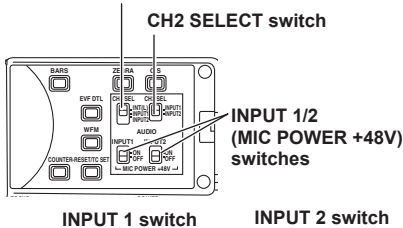

INPUT 1 switch

INPUT 2 switch

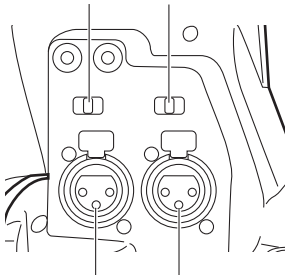

INPUT 1 terminal

INPUT 2 terminal

Using the built-in microphone

- 1 **Switch the CH1 SELECT switch to INT (L).**
 - Audio from the built-in microphone Lch is recorded to audio channel 1.
- 2 **Switch the CH2 SELECT switch to INT (R).**
 - Audio from the built-in microphone Rch is recorded to audio channel 2.

Using an external microphone and audio equipment

- 1 **Connect an external microphone or audio equipment to the INPUT 1/2 (XLR 3-pin) terminals. (Page 41)**
- 2 **Use the INPUT 1/2 switches to switch the audio input.**

LINE: (audio equipment is connected)
Input level is 0 dBu.

MIC: (an external microphone is connected)
Input level is -50 dBu.

You can change the input level to -60 dBu in the setup menus, RECORDING SETUP screen MIC GAIN1 and MIC GAIN2. (Page 56)
Be aware that sensitivity will be higher if you choose -60 dBu so you will record more noise.
- 3 **When using the phantom microphone (which requires + 48V power supply), set the INPUT 1/2 (MIC POWER +48V) switches to ON.**

ON: (When using the phantom microphone)
+48V power supply to INPUT 1/2 terminals.

OFF: (When a phantom microphone is not connected)
No power supply for INPUT 1/2 terminals.

 - The battery will discharge faster if you use a phantom microphone.
 - Set to OFF if you connect equipment not compatible with +48V. You can damage such equipment if you leave the setting at ON.
 - When using the AG-MC200G (optional), set the MIC GAIN item to -50 dBu.

4 Use the CH1 SELECT switch to select the input signal to be recorded to audio channel 1. INT (L):

Audio from the built-in microphone Lch is recorded to audio channel 1.

INPUT 1:

Audio from a device connected to INPUT 1 terminal is recorded to channel 1.

INPUT 2:

Audio from a device connected to INPUT 2 terminal is recorded to channel 1.

5 Use the CH2 SELECT switch to select the input signal to be recorded to audio channel 2. INT (R):

Audio from the built-in microphone Rch is recorded to audio channel 2.

INPUT 2:

Audio from a device connected to INPUT 2 terminal is recorded to channel 2.

-
- When inputting the microphone signal to channels 1 and 2, connect the microphone to INPUT 2 and switch both CH1 SELECT and CH2 SELECT to INPUT 2.
-

Adjusting the recording level

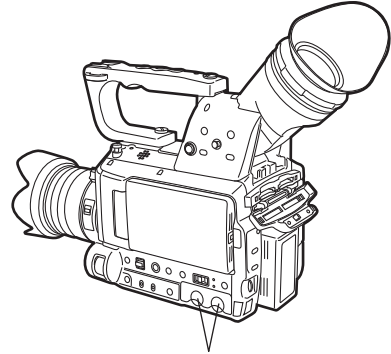

AUDIO control knobs

Use the AUDIO control knobs to adjust the recording level of the built-in microphone or of audio signals input through the INPUT 1/2 (XLR 3-pin) terminals.

To adjust the volume of the sound for monitoring. (Page 12)

To adjust the recording level of the audio signals, turn the AUDIO control knobs while referring to the audio level meter at the bottom left of the viewfinder and LCD monitor, regardless of the MIC ALC option setting (Page 56) on the RECORDING SETUP screen of the setting menu.



-
- Check the recording volume level prior to shooting.
 - The recording level of this camera is set approximately 8 dB higher than Panasonic broadcasting camera recorders (AJ series products).
-

Using scene files

The settings according to the variety of shooting circumstances are stored SCENE FILE MENU. They are selected via the SCENE SELECT on the settings menu SCENE FILE screen.

When the camera-recorder is shipped from the factory, the following files are stored.

F1:

File suitable for normal shooting.

F2: FLUO.

File suitable for shooting under fluorescent lights, ie. indoors.

F3: SPARK

File suitable for shooting with fuller variations of resolution, coloring and contrast.

F4: B-STR

File for broadening the contrast of dark parts, such as when shooting sunsets.

F5: CINE V

File suitable for shooting movie-like scenes where the contrast is to be emphasized. (The recording format remains unchanged even when the scene file is changed. It must be set using the REC FORMAT item on the SCENE FILE screen. (Page 51))

F6: CINE D

File suitable for shooting movie-like scenes where the dynamic range is to be emphasized. (The recording format remains unchanged even when the scene file is changed. It must be set using the REC FORMAT item on the SCENE FILE screen. (Page 51))

Changing scene file settings

The setting value of the scene file can be changed. Also you can save the changed scene file to each position of the SCENE FILE dial.

Example: Change the name of the scene file.

- 1 Set the POWER switch to ON.**
- 2 Select the scene file to be changed in the SCENE FILE MENU.**
- 3 In the setup menus, select the SCENE FILE screen.**
 - For menu operation (Page E-44 of Vol.1)
 - Operations may also be performed using buttons on the remote control that correspond to those on the camera. For details, see "Description of parts (Remote control)". (Page E-23 of Vol.1)
- 4 Tilt the Operation lever in the ▲ ▼ directions and select the NAME EDIT item.**
- 5 Push the Operation lever (or tilt in the ► direction), tilt in the ▲ direction to select YES, and push the Operation lever again.**

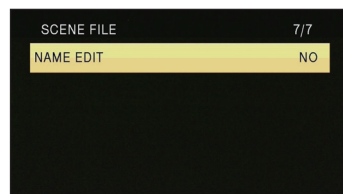

6 Set a 6-character filename with the Operation lever when the following screen is displayed.

Set the same as user information. (Page 27)

- Characters that can be set
Space, A to Z, 0 to 9, ; ; < = > ? @ [¥] ^ _ - /
If the RESET/TC SET button is pressed when the filename has been set, the characters are cleared.

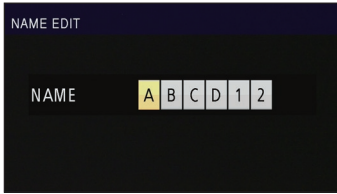

7 After you finish setting the filename, push the Operation lever.

- 8 Select YES on the confirmation screen.**
- Selecting YES will close the NAME EDIT screen and confirm all changes.
 - Once confirmed, all changed names and values will be saved even if the power is switched off or the scene dial is moved.

Saving scene files and other settings on SD Memory Cards

You can save up to four scene file settings or other settings as files on an SD Memory Card, and you can also load them from the card.

- In the case of the scene files, the current settings are automatically saved in the unit, and the saved data is written on an SD Memory Card. When data has been read from an SD Memory Card, the current settings are rewritten at the same time as the data saved inside the unit.
- The data in all the scene files, F1 to F6, is rewritten.

If you have saved a scene file

- 1 Set the unit's POWER switch to ON.**
- 2 Select the slot number for the SD memory card onto which you wish to save from the CARD WRITE option on the settings menu SCENE FILE screen, and press the OPERATION lever.**

For all other settings, select USER FILE.

- For menu operations (Page E-44 of Vol.1)
- Operations may also be performed using buttons on the remote control that correspond to those on the camera. For details, see "Description of parts (Remote control)". (Page E-23 of Vol.1)

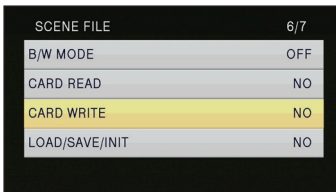

- 3 Tilt the Operation lever in the ▲▼ directions, select the file number (1 - 4), and push the OPERATION lever.**

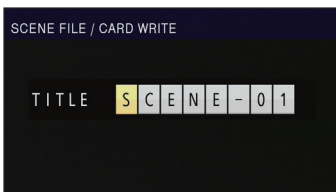

- 4 Push the Operation lever again, select YES when the following screen is displayed, and push the OPERATION lever.**

- In the following example, SCENE-01 is the TITLE name. To change the TITLE name, see the description below.

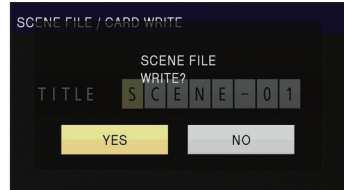

- 5 Press the MENU button to exit the menu mode.**

To read files

- 1) Select READ in step 2 and push the Operation lever.
- 2) Select the file number and push the Operation lever.
- 3) Select YES on the confirmation screen. READ COMPLETED will be displayed when reading is complete.

To add titles to files

- 1) Go through steps 1 - 3.
- 2) Tilt the Operation lever in the ▲▼ directions to select characters, and tilt in the ► direction to move to the next character.
The following characters may be inputted.
(Space), A-Z, 0-9, ; < = > ? @ [¥] ^ _ - . /
- 3) Push the Operation lever when all characters have been inputted.
- 4) Select YES on the confirmation screen.

-
- If WRITE PROTECT appears, release the protected status of the SD Memory Card.
 - If WRITE NG CANNOT ACCESS appears, quit all other operations (such as playback) before proceeding.
-

Clip metadata

You can add the video and audio systems, name of the videographer, shooting location, text memos and other information to the video data you have recorded on the SD Memory Card. This data is called the clip metadata.

(Display method: Page 38)

There are two kinds of clip metadata: the data that is recorded automatically during shooting, and the data in the metadata upload file created on the SD Memory Card which is loaded in the unit.

(Loading method: Next page)

What the clip metadata consists of

You can set the items underlined below by loading the metadata upload file on the SD Memory Card. All other items are set automatically during shooting.

GLOBAL CLIP ID:

This indicates the global clip ID that shows the shooting status of the clip.

USER CLIP NAME :

This indicates the name of the clip that the user has set.*1

VIDEO & AUDIO:

This indicates the recorded image's FRAME RATE, RESOLUTION, PULL DOWN system and AUDIO.

LENS:

This indicates the MAKER, MODEL, and SERIAL No. of your lens.

ACCESS:

This indicates the CREATOR (name of the person recording), CREATION DATE (recording date), LAST UPDATE DATE (date on which the data was last updated) and LAST UPDATE PERSON (the person who last updated the data).

DEVICE:

This indicates the MANUFACTURER (manufacturer of the equipment), SERIAL NO. (serial number of the equipment) and MODEL NAME (Equipment model name: AG-AF100 for this camera-recorder).

SHOOT:

This indicates the SHOOTER (name of the videographer) and the PLACE NAME (name of location).

LOCATION:

This indicates ALTITUDE, LONGITUDE, LATITUDE, and SOURCE (altitude, longitude, latitude, information source). Not recorded in this camera-recorder.

SCENARIO:*2

This indicates the PROGRAM NAME, SCENE NO. and TAKE NO.

NEWS 1:

This indicates the REPORTER (name of the reporter) and PURPOSE (purpose of data collection).

NEWS 2:

This indicates the OBJECT (target of data collection).

MEMO:*3

This indicates the PERSON (name of the person who recorded the text memo) and TEXT (contents of memo).

*1 If there is no information in the metadata upload file, consecutive five-digit numbers will be applied to the clips in the order that they were recorded, with the first clip to be recorded being given the number 0. The USER CLIP NAME recording method is selectable. Please refer to the page 23.

*2 When SCENARIO is to be input, you must input the PROGRAM NAME. You cannot input the SCENE NO. and TAKE NO. only.

*3 When MEMO is to be input, you must input TEXT. You cannot input PERSON only.

-
-
- Only printable ASCII characters can be displayed by this unit.
 - Due to the limitations imposed by this unit on the number of characters which can be displayed, not all the data can be displayed. (This does not mean that the data which is not displayed has been deleted.) Use an AVCCAM viewer or other program to check all the data.
 - Metadata can be produced with AVCCAM Viewer. (Page 73)
-
-

Uploading the metadata (META DATA)

You can perform any of the following operations. If necessary, make preparations prior to undertaking the operations.

Loading the metadata

- Insert the SD Memory Card on which the metadata is recorded into the unit. (For details on contents of the metadata, see the previous page.)

Selecting whether to record the metadata on the SD Memory Card

Initializing the metadata inside the unit

Displaying the metadata inside the unit

- 1 Press the mode button and select **CAM** mode.
- 2 Press the **MENU** button.
Menu operation (Page E-44 of Vol.1)
- 3 Tilt the lever in the **▲ ▼** directions to select **META DATA**, and push the Operation lever (or tilt in the **▶** direction).

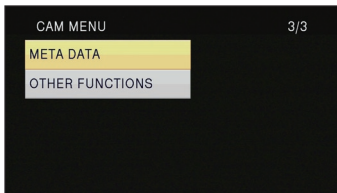

- 4 Tilt the Operation lever in the **▲ ▼** directions to select item, and push the Operation lever.

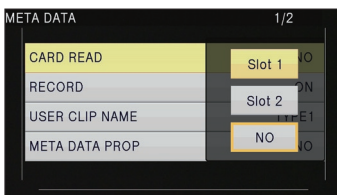

CARD READ:

Read metadata set to the SD Memory Card with the camera.

Move to **LOAD**, push the Operation lever, select whether or not to read the metadata (YES/NO), and push the Operation lever again.

- Up to 10 items of metadata on the SD Memory Card can be displayed, starting from the most recent date of production.
- If characters other than single-byte alphanumeric characters are used in the metadata file name to be loaded, they are displayed as "*".

RECORD:

Select this to set whether to record the metadata to be loaded into the unit simultaneously on the SD Memory Card. Select ON to record the metadata or OFF to cancel the recording, and push the Operation lever. The factory setting for this mode is OFF.

USER CLIP NAME:

The USER CLIP NAME recording method is selectable. Please refer to the next column below.

META DATA PROP:

Select this to display the metadata which has been recorded in the unit.

CLIP COUNT RESET:

Reset the counter value to 1. Select whether or not to reset (YES/NO), and push the Operation lever.

META INIT SET:

Select this to initialize the metadata which has been recorded in the unit. Select YES to initialize the metadata or NO to cancel the initialization, and push the Operation lever.

- 5 Press the **MENU** button to release the menu mode.

Selecting the USER CLIP NAME recording method

Press the **MENU** button and select **META DATA** → **USER CLIP NAME** to select the recording method. Two options are available: **TYPE1** and **TYPE2**.

USER CLIP NAME to be recorded

	TYPE1	TYPE2
If clip metadata has been read in	Uploaded data	Uploaded data + COUNT value*
If no clip metadata has been read in or if the setting for recording clip metadata has been turned off	Sequential 5-digit number, in order of recording	Sequential 5-digit number, in order of recording

Clip metadata (continued)

* The COUNT value is indicated as a four-digit number. The COUNT value is incremented each time a new clip is captured if clip metadata has been read in and TYPE2 has been selected as the recording method.

The COUNT value can be reset using the following procedure.

Press the MENU button, select META DATA→CLIP COUNT RESET→YES, and push the Operation lever to reset the counter value to 1.

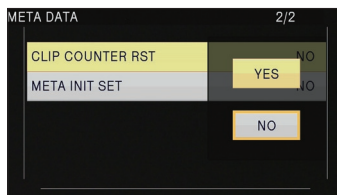

Using the Counter

Counter display

You can display a counter that indicates how much time has elapsed during shooting or playback.

1 Press the COUNTER button.

Each time you press the button, the display changes as follows. (Page 45)

0 : 00. 00 (CAM mode only)

Counter value

Displayed when TOTAL is selected from the REC COUNTER item in the DISPLAY SETUP screen of MENU settings.

CLIP 0 : 00 . 00

Displayed when CLIP is selected in the REC COUNTER item on the settings menu DISPLAY SETUP screen.

Values are automatically reset when recording is started, and counter values are displayed for each individual clip.

TC 12 : 34 : 56 . 01

Time code value (Display time code frame digits in 24 frames when 24P is set, and in 30 frames when any other format is set.)

UB 12 34 56 78

User information

No display:

Data is not displayed.

TC preset mode

When shooting using a multi-camera, you can synchronously set the initial values of time code. The camera used for synchronization is the MASTER and the camera being synchronized is the SLAVE.

1 Connect the TC PRESET IN/OUT terminals (VIDEO OUT terminals) on the two devices with a pin cable, and turn on the power.

■ MASTER settings

2 Check that the MASTER camera is set to the CAM mode, and set the EXT TC LINK item on the setting menu TC/UB SETUP screen to MASTER.

OUTPUTTING LTC SIGNAL is displayed on the screen, and the time code is output from the TC PRESET IN/OUT terminal (VIDEO OUT terminal).

- Select the same REC FORMAT setting for both the MASTER and SLAVE cameras, and set the TCG item on the TC/UB SETUP screen to FREE RUN.
- To cancel the time code output, press the MENU button.

■ SLAVE settings

3 Set the EXT TC LINK item on the setting menu TC/UB SETUP screen to SLAVE.

4 Press the COUNTER - RESET/TC SET button. TCG values will be reset to the TC values inputted from the MASTER.

- TC LINK OK will be displayed for approximately 2 seconds when the menu screen is closed.
- If the TC values cannot be set correctly, LINK NG will be displayed.
- If the SLAVE device is set to 24P, please set the TC MODE item on the MASTER device to NDF.
- To cancel the SLAVE mode, press the MENU button.

Charging the built-in battery/Setting the time code

Recharging the built-in battery

The camera's internal battery saves the date and time.

When LOW INTERNAL BATTERY (indicating that the internal battery has no remaining charge) is displayed even when the date and time are set, it means that the charge of the internal battery is depleted. Do the following to recharge it. Reset the date and time when fully recharged.

- 1 Connect the AC adaptor. (Page E-25 of Vol.1)**
 - Leave the POWER switch at OFF.
- 2 Leave the camera-recorder like this for about 4 hours.**
 - The internal battery charges during this time.
 - Check the time code and menu operations after recharging.

If the date and time are not memorized after recharging, the internal battery requires changing. Please consult the place of purchase.

Setting the time code

In the setup menus, TC/UB SETUP screen, set the following time code related items. (Page 57)

- TC MODE
- TCG
- TC PRESET

Specifying the time code (TC PRESET)

Set TC PRESET so you can record a value of your choice as the initial setting for the time code to be used at the start of recording.

- 1 Set the POWER switch to ON.**
- 2 Select the TC PRESET item in the settings menu TC/UB SETUP screen.**
 - For menu operation (Page E-44 of Vol.1)
 - Operations may also be performed using buttons on the remote control that correspond to those on the camera. For details, see "Description of parts (Remote control)". (Page E-23 of Vol.1)
- 3 Tilt the Operation lever in the ▲ direction to move to YES, and push the Operation lever.**

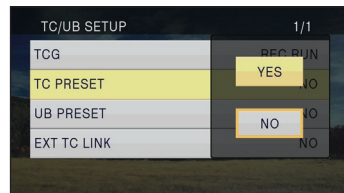

Charging the built-in battery/Setting the time code (continued)

4 When the screen below appears, set the time code value.

Tilt the Operation lever in the ▲ ▼ directions and select time code value.

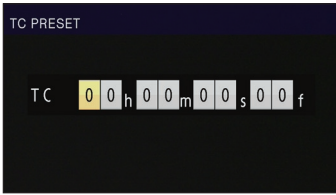

Tilt in the ► direction to move to the next digit, and tilt in the ▲ ▼ directions again to select value.



With this unit, the time code value is adjusted in accordance with the format and frame rate. For this reason, bear in mind that making a change in the format or frame rate may result in discontinuity from the last time code value of the previous recording.

Adjustments are made in 4-frame increments when the recording format is 24P.

Recording format	Time code adjustment
1080/24P	Adjustable in 4-frame increments
720/24P	

You can reset the time code to zero by pressing RESET/TC SET button.

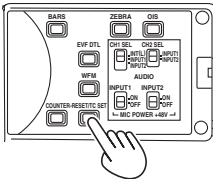

Camera

5 Push the Operation lever when you have finished setting the time code.

6 Tilt the Operation lever in the ◀ direction to move to YES, and push the Operation lever.

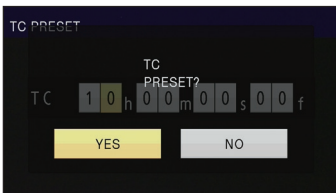

Setting user information

Setting user information allows you to store 8-digit information in the hexadecimal format.

User information is automatically saved in the memory and retained after you turn off the power.

- 1 Set the POWER switch to ON.
- 2 In the setup menus, TC/UB SETUP screen, select UB PRESET.
 - For menu operation (Page E-44 of Vol.1)
 - Operations may also be performed using buttons on the remote control that correspond to those on the camera. For details, see “Description of parts (Remote control)”. (Page E-23 of Vol.1)
- 3 Tilt the Operation lever in the ▲ direction to move to YES, and push the Operation lever.

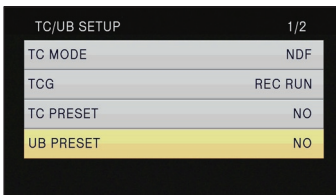

4 Set the user information.

Tilt the Operation lever in the ▲▼ directions and select user information characters.

- You can use numbers from 0 to 9 and letters from A to F.



Tilt in the ► direction to move to the next digit, and tilt in the ▲▼ directions again to select character.

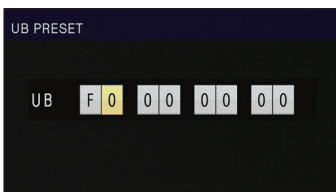

You can reset the user information to nothing by pressing RESET/TC SET button.

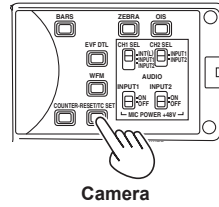

- 5 Push the Operation lever when you have finished setting the user information.
- 6 Tilt the Operation lever in the ◀ direction to move to YES, and push the Operation lever.



Basic playback operations

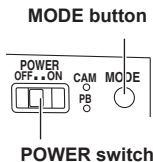

- 1 Turn the POWER switch to ON.
- 2 Press the mode button so the PB lamp turns on.

The camera is now in the PB mode.

- Each time you press the button, the mode changes as below.

PB ↔ CAM

For details on playing back clips using thumbnails, see page 29.

Operations using the Operation lever		Remote control
	<p>Play (▶)</p> <p>Press to play the clip currently indicated by the cursor.</p>	
	<p>Fast forward (▶▶)</p> <p>Press during playback to scroll quickly through the clip at approximately 10 times the speed.</p> <p>Repeat the operation to scroll quickly at approximately 20 times the speed.</p> <p>Press <u>while paused</u> to move to the next clip.</p>	
	<p>Rewind (◀◀)</p> <p>Press during playback to scroll quickly backwards through the clip at approximately 10 times the speed.</p> <p>Repeat the operation to scroll quickly backwards at approximately 20 times the speed.</p> <p>Press <u>while paused</u> to move to the previous clip.</p>	
	<p>Stop (■)</p>	
	<p>Pause ()</p> <p>Press during playback to pause the clip.</p> <p>Press again to return to normal playback.</p>	

Thumbnail screen

Video data created in one shooting session is called a clip. When the PB mode has been established, the clips will be displayed on the LCD monitor and the viewfinder as thumbnails. (When there is a large number of clips, it will take some time for them to be displayed on the screen.)

You can perform the following operations using the thumbnail screen.

- Play and delete clips
- Format SD Memory Card
- Add or delete index
- Add or delete shot mark

Basic thumbnail screen operations

To select thumbnail:

Tilt the Operation lever in the ▲▼◀▶ directions to select thumbnail (Orange frame moves).

To play back clips:

Select the thumbnail, and push the Operation lever. (For details on playback, see page 28.)

To change the slot for playback:

Press the SLOT SELECT button to select the slot.

To play back still images:

Press the SLOT SELECT button to select the slot.

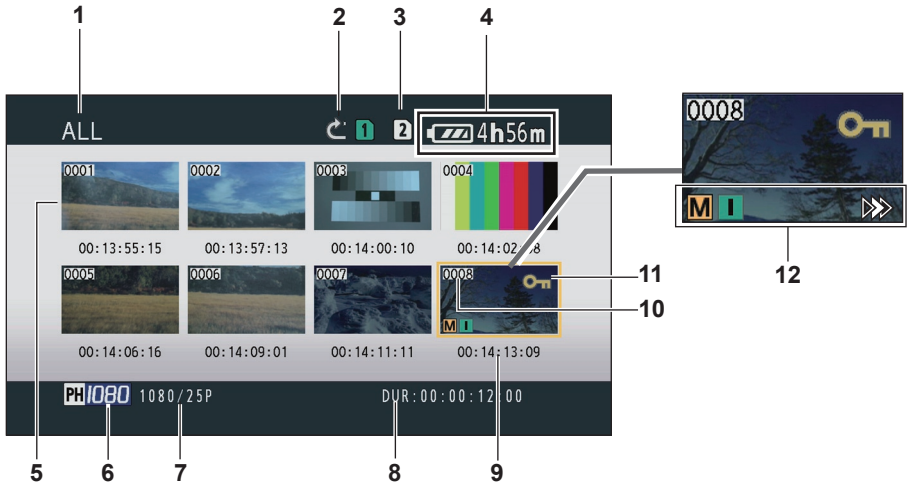
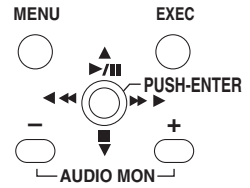

- 1 Thumbnail display status (Page 34)**

The types of clips displayed as thumbnails appear in this area.
- 2 Repeat playback indicator (Page 32)**

Displayed during repeat playback.
- 3 Card status display**

Displays status of SD Memory Card.
- 4 Battery remaining display (Page E-24 of Vol.1)**

Displays remaining battery capacity.
- 5 Cursor (Orange frame)**

Displayed on currently selected thumbnail.
- 6 Recording mode display**

Displays recording mode if clip currently highlighted by cursor has been recorded in PH mode.
- 7 Recording format display**

Displays recording format of currently selected clip.
- 8 Duration display**

Displays duration of currently selected clip.
- 9 Time display (Page 34)**

Displays time code at start of clip recording/ user information at start of clip recording/time of recording/date of recording/date and time of recording – according to settings.
- 10 Clip number**

Displayed in order of recording (up to 1000 clips). Numbers of clips that cannot be played back (e.g. clips of different recording formats) are displayed in red. To play clips displayed in red, set the PB format in the settings menu PLAY SETUP screen to the appropriate recording format (Page 64).
- 11  : Clip protect display**

Displayed on protected clips.
- 12 Indicators**
 -  : Shot mark**

This indicates that a clip has a shot mark.
(Next page)
 -  : Index**

Displayed when indexes have been attached (Page 35).
 -  : Resume playback display**

Displayed on clips on which resume playback setting has been applied.

Adding shot marks to clips

Adding shot marks (**M**) will make it easier to find the clips you are looking for.

1 Tilt the Operation lever in the ▲▼◀▶ directions to move the yellow frame to the clip for which a shot mark is to be added.

2 Press the USER button to which the shot mark function has been allocated. (Page 55)

To release a shot mark, repeat the above steps.

- It is not possible to add shot marks to clips recorded using a consumer camcorder model.

Select the card slot for playback

You can switch the SD memory card slot for playback.

1 Press the SLOT SELECT button when the THUMBAIL screen is displayed in the PB mode.



2 Tilt the OPERATION lever in the up, down, left, and right directions to select the SD memory card slot for playback. You can play back still images as well.

VIDEO:

Movie playback

PICTURE:

Still picture playback

3 Push the OPERATION lever.

Playback settings (PLAY SETUP)

Make settings for playback format and method.

Set playback format (PB FORMAT)

Set format for playback.

- 1 Press the MENU button.**
Menu operation (Page E-44 of Vol.1)
- 2 Select the PB FORMAT item in the PLAY SETUP screen, and push the Operation lever (or tilt in the ► direction).**

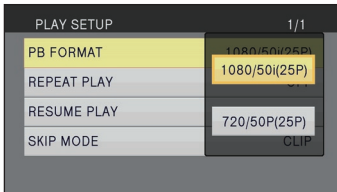

- 3 Tilt the Operation lever in the ▲ ▼ directions to select the format for playback, and push the Operation lever.**
 - The setting for the REC FORMAT item on the setting menu SCENE FILE screen is reflected as the initial setting.
 - Clip numbers will be displayed in black where playback is possible, and in red where playback is not possible.

-
- Even if the playback format is changed, the format set in the REC FORMAT item on the settings menu SCENE FILE screen will be restored when the camera is switched to CAM mode.
 - If the playback format does not conform to the clips created at the relay destination using the relay recording function, thumbnail images will not be displayed (! will be displayed). Thumbnail images will be displayed when the playback format is matched to the clips.
-

Repeat playback (REPEAT PLAY)

Use this setting to repeatedly play back all available clips.

- 1 Press the MENU button.**
Menu operation (Page E-44 of Vol.1)
- 2 Set the REPEAT PLAY item in the PLAY SETUP screen to ON.**
- 3 Press the MENU button to return to the thumbnail screen.**
The repeat playback indicator will be displayed. When the playback operation is performed, the playable clips are played back repeatedly.
 - Repeat playback will continue until playback is paused.
 - To turn the repeat playback setting off, select OFF in step 2.

Resume playback (RESUME PLAY)

Use this setting to play back from where clip had previously been paused.

- 1 Press the MENU button.**
Menu operation (Page E-44 of Vol.1)
- 2 Set the RESUME PLAY item in the PLAY SETUP screen to ON.**
- 3 Press the MENU button to return to the thumbnail screen.**
- 4 Select a clip for playback.**
If playback has previously been paused, the resume playback indicator will be displayed on the clip thumbnail, and the remainder of the clip will be played next time the clip is selected for playback.
 - To turn the resume playback setting off, select OFF in step 2.

Set skip method (SKIP MODE)

Select which skip (cue) operation is to be performed when playback is paused.

- 1 Press the MENU button.**
Menu operation (Page E-44 of Vol.1)
- 2 Select the SKIP MODE item in the PLAY SETUP screen.**
- 3 Select skip method.**
CLIP:
Move to the beginning of the previous or next clip by tilting the Operation lever in the ◀ or ▶ direction while playback is paused.
CLIP & INDEX:
Move to the beginning of the previous or next clip, or to the previous or next INDEX position, by tilting the Operation lever in the ◀ or ▶ direction while playback is paused.
- 4 Press the MENU button to return to the thumbnail screen.**

Thumbnail operations

Selecting the thumbnail display method (THUMBNAIL)

You can display the kind of clips you want to see as thumbnails.

You can also set more precisely how you want the thumbnails to appear on the screen.

- 1 Press the MENU button.**
Menu operation (Page E-44 of Vol.1)
- 2 Select the THUMBNAIL screen, and push the Operation lever (or tilt in the ► direction).**
- 3 Tilt the Operation lever in the ▲ ▼ directions to select item, and push the Operation lever.**

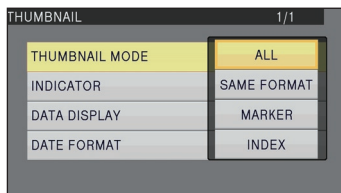

THUMBNAIL MODE:

Select the clips to be displayed.

ALL:

Display all clips.

SAME FORMAT:

Display all clips of the same format as the current PB format.

MARKER:

Display all clips with shot marks.

INDEX:

Display all clips with indexes.

INDICATOR:

Set whether or not to display indicator (ON/OFF). (Factory default setting is ON.)

Clip protect display and resume playback display will still appear even if this setting is set to OFF.

DATA DISPLAY:

Select format of clip time display – time code (TC)/user information (UB)/recording time (TIME)/recording date (DATE)/ recording date and time (DATE & TIME). If recording time (TIME) is selected, the display will be in the format "Month-Day Time".

DATE FORMAT:

Select display order for recording date - year-month-date (Y-M-D)/month-date-year (M-D-Y)/date-month-year (D-M-Y).

This setting will not be reflected in CLIP PROPERTY.

- 4 Press the MENU button to return to the thumbnail screen.**

Deleting and protecting clips (OPERATION)

Clips may be deleted or protected.

- 1 Press the MENU button.**
Menu operation (Page E-44 of Vol.1)
- 2 Select the OPERATION screen, and push the Operation lever (or tilt in the ► direction).**

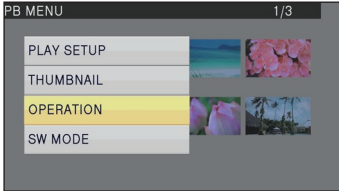

- 3 Tilt the Operation lever in the ▲ ▼ directions to select item, and push the Operation lever.**

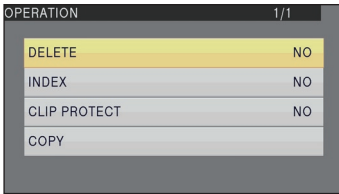

DELETE:

ALL CLIPS:
Delete all clips.
Select whether or not to delete (YES/NO), and push the Operation lever.

SELECT:
Delete selected clips.
Select clips with the Operation lever. If clips are selected with the OPERATION lever, the selected clips appear within a red frame. (Repeat this operation to select multiple clips.)
Press the EXEC button to confirm, tilt the Operation lever in the ▲ ▼ directions to select whether or not to delete (YES/NO), and push the Operation lever.

NO:
Return to the previous screen.

- Protected clips cannot be deleted.
- If selecting ALL CLIPS to delete all clips from the memory, this operation may take some time to complete, depending on the volume of clips to be deleted.
- Deletion cannot be performed via the remote control.
- To abort deletion, press the CANCEL button. The already deleted clips cannot be restored even if the deletion process is aborted.

INDEX:

YES:
Attach indexes to selected clips.
1) Select clip to play, and push the Operation lever at the point for an index to be added.



- 2) Select YES on the confirmation screen to attach index.
- The point in the clip at which the index will actually be attached will be accurate to within an error of 0.5 seconds.
- To delete index, select INDEX→YES in step 3 before performing the following.
 - 1) Select clip to play, tilt the Operation lever in the ▲ direction, and pause the clip.
 - 2) Tilt the Operation lever in the ◀▶ directions to move the pointer between the points where indexes are attached. Move the pointer to the index to be deleted, and push the Operation lever.
 - 3) Select YES on the confirmation screen.

NO:
Return to the previous screen.

- It is not possible to add indexes to clips recorded using a consumer camcorder model.
- It is not possible to adjust the volume during index playback.

CLIP PROTECT:

YES:

Protect selected clips.

(**On** mark will be displayed.)

- Cancel protection when the protected clip is selected.

(**On** mark will disappear.)

Executing a format of the memory card (see below) will delete all clips even if they are protected.

NO:

Return to the previous screen.

4 Press the MENU button to return to the thumbnail screen.

Copying clips (COPY)

Clips recorded onto SD cards can be copied onto other SD cards.

1 Insert the SD card containing the clip you wish to copy into one of the SD card slots.

2 Insert the card you wish to copy the clip onto into the other SD card slot.

- Clips cannot be copied if there is not enough space available on the target card.

3 Select COPY from OPERATION of the PB MENU.

4 Select the type of data to be copied.

VIDEO&PICTURE:

Video images and photograph data

VIDEO:

Video images only

PICTURE:

Photograph data only

5 Select copy method.

Copying VIDEO

ALL CLIPS:

All scenes

SELECT CLIPS:

Select scenes.

SAME FORMAT:

Scenes of the same format as the current PB format

INDEX:

Scenes with INDEX input

MARK:

Scenes with scene MARK input

Copying PICTURE

ALL SCENES:

All scenes

SELECT CLIPS:

Select scenes.

6 Select start copy.

Do not open the SD card slot covers or switch the camera off during copy operations.

- The copy function will not operate if the remaining battery capacity is insufficient. Exchange the battery for a charged one, or use the AC adaptor.

Clips recorded with AG-3DA1 cannot be selected for copying in this camera. Clips that cannot be played back in this camera cannot be selected as well. However, pictures that cannot be played back in this camera can be selected and copied.

Format card and check clip and card information (CARD FUNCTIONS)

SD Memory Cards can be formatted, and clip and SD Memory Card information can be checked.

1 Press the MENU button.

Menu operation (Page E-44 of Vol.1)

2 Select CARD FUNCTIONS, and push the Operation lever (or tilt in the ► direction).

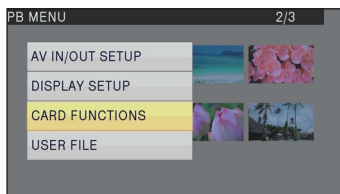

3 Tilt the Operation lever in the ▲▼ directions to select item, and push the Operation lever.

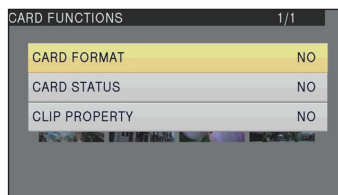

CARD FORMAT:

- Insert card to be formatted into the camera.
- SD Memory Card will be formatted.
Proceeding will delete the entire data, including videos and picture data, from the card.
Select whether or not to format (YES/NO), and push the Operation lever.

CARD STATUS:

Display SD Memory Card information.
(Next page)

CLIP PROPERTY:

Display information of selected clip.
(Next page)

- Tilt the Operation lever in the ◀▶ directions to display information from previous or subsequent clips.

4 Press the MENU button to return to the thumbnail screen.

Thumbnail operations (continued)

SD Memory Card information screen

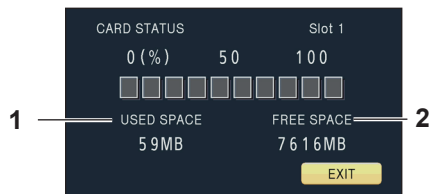

1 USED SPACE :

Used space

2 FREE SPACE :

Available space

Clip information screen

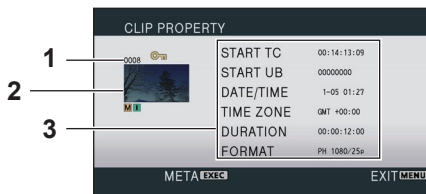

1 Clip number

2 Thumbnail (Thumbnail screen: Page 29)

3 Clip information

Displays data attached to the clip.

START TC: Time code value at start of recording

START UB: User information value at start of recording

DATE/TIME: Date of recording at time at start of recording

TIME ZONE: Displays time zone.

DURATION: Clip length

FORMAT: Recording format

• Clip meta data

Press the EXEC button while the clip information screen is being displayed to display more detailed information, including video and audio formats, and information about the videographer, etc.

Tilt the Operation lever in the ▲ ▼ directions to verify the desired information. (Please see page 22 for more information on clip metadata.)

Useful playback functions

Fast forward/rewind

- 1 Tilt the Operation lever in the ◀◀ (rewind) or ▶▶ (fast forward) direction during playback (or press the SEARCH buttons on the remote control).

Clip will play forwards/backwards at approximately 10 times the normal speed. Repeat the operation to play the clip forwards/backwards at approximately 20 times the normal speed.

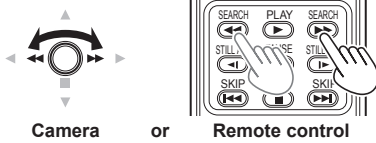

Next/previous clip

- 1 Tilt the Operation lever in the ▲ direction during playback to pause the clip (or press the PAUSE button on the remote control).
- 2 Tilt the Operation lever in the ◀◀ (rewind) or ▶▶ (fast forward) direction during playback (or press the SKIP buttons on the remote control).

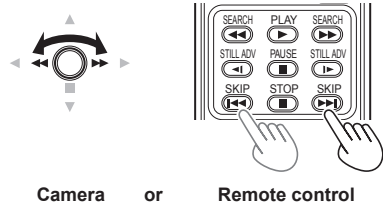

To return to normal playback, tilt the Operation lever in the ▲ direction (play) (or press the PLAY button on the remote control).

- The screen will return to the thumbnail display after the playback of the last clip is completed during fast forward playback.
- The screen will pause at the first clip after the fast rewind playback of the first clip is completed.
- No audio will be played during fast forward or rewind playback.

Frame-by-frame playback

- 1 Tilt the Operation lever in the ▲ direction during playback to pause the clip (or press the PAUSE button on the remote control).
- 2 Press the AUDIO MON/ADV buttons (or press the STILL ADV buttons on the remote control).
 - Hold down to continuously advance frame by frame until the button is released.
 - Hold down the STILL ADV button on the remote control to continuously advance frame by frame. Press the PAUSE button to cancel.

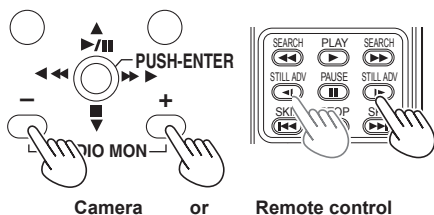

Camera or Remote control

When the + button is pressed, the images are advanced in the forward direction, and when the - button is pressed, they are advanced in the reverse direction at half-second intervals.

To return to normal playback, tilt the Operation lever in the ▲ direction (play) (or press the PLAY button on the remote control).

Adjust volume

- 1 The volume of audio output from the internal speaker and headphone jack can be adjusted with the AUDIO MON/ADV buttons during playback. Press the ZOOM/VOL buttons if using the remote control.

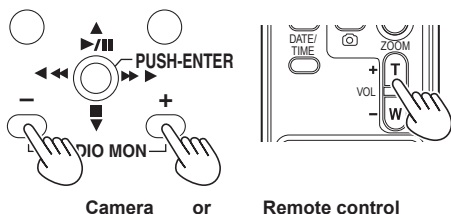

Camera or Remote control

Viewing images on a television

You can view the images on a television if you connect the unit to a television set using an AV cable (not included) or HDMI cable (not included).

- 1 Connect the camera-recorder to the TV set. (Page 42)
- 2 Start playback.
 - To show the information that appears on the viewfinder and LCD on a television, press the EXT. DISPLAY button on the remote control. Press the EXT. DISPLAY button again to clear the display.

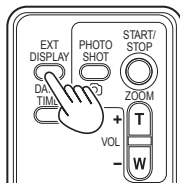

Checking the date and time

Press the DATE/TIME button on the remote control to show the date and time of shooting on the viewfinder and the LCD monitor. The display changes as follows each time you press the button.

Time
↓
Date
↓
Time and Date
↓
No display

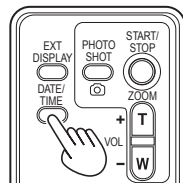

Connecting external units

Headphones

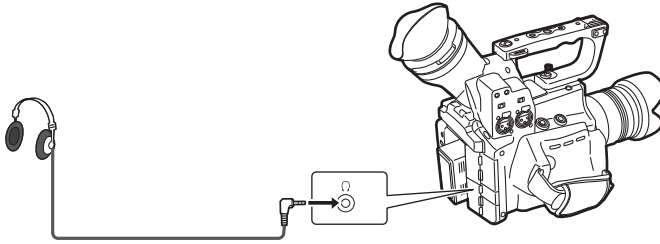

3.5-mm stereo mini jack

- Sound is no longer heard from the speaker when the headphones (optional) are connected.

Editing

External microphone

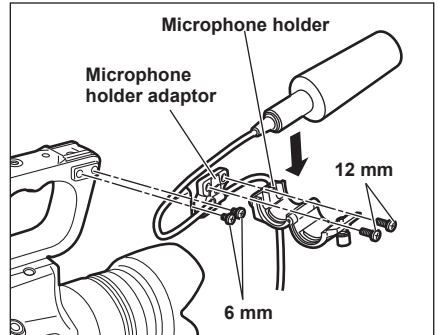
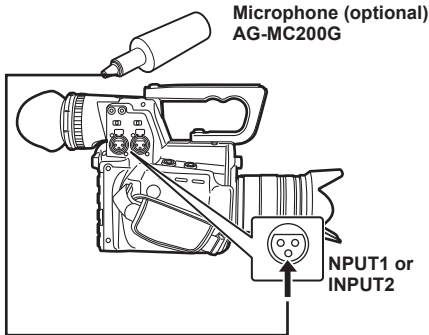

- When attaching an external microphone to the microphone shoe, use the supplied microphone holder and microphone holder adaptor.
- When attaching the microphone holder and the microphone holder adaptor, be sure to tighten the screws firmly even though you might hear a squeaking sound.
- The microphone holder mounting position is provided at two locations, namely in the handle and on top of the INPUT 1 and INPUT 2 terminals. If the microphone holder is mounted on the handle, the microphone may be captured if a wide-angle lens is used. Select the mounting location after checking the images.
- When wiring the microphone cable, use either the cable clammer of the microphone holder adaptor, or the included cable clammer.

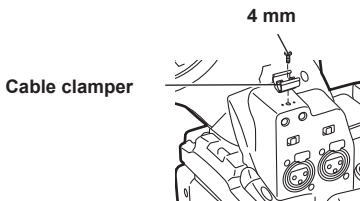

Connecting external units (continued)

Computer (non-linear editing/file transfer)

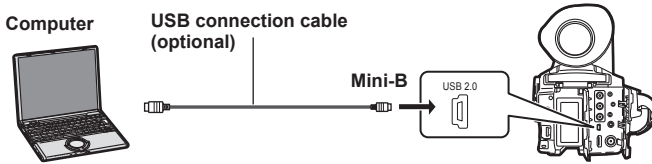

- For details on the computer's conditions and other factors, see page 44.
- Use a double-shielded USB connection cable with a maximum length of three meters.

TV/Monitor

Only the output signals from the camera are shown.

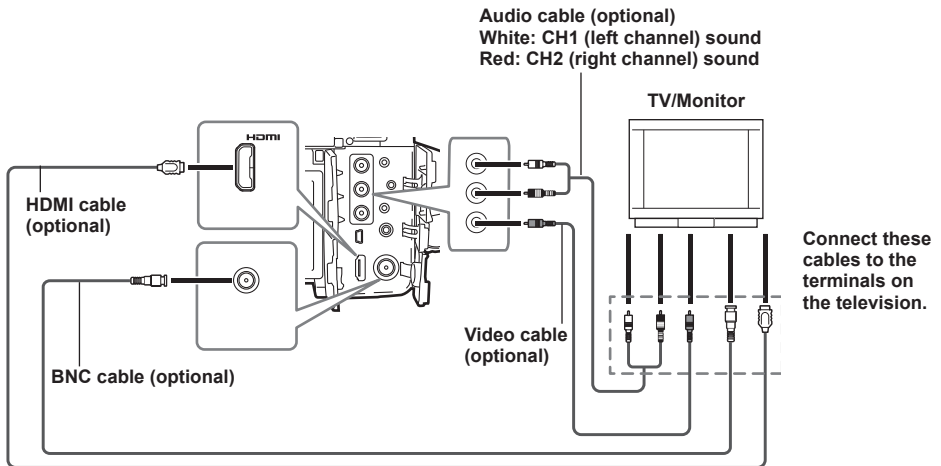

■ **When outputting video and audio signals from the camera to an external device, connect to the input terminals of the external device.**

- Use a double-shielded HDMI cable (not included).
- It is recommended that you use Panasonic's HDMI cable.
- This product is not compatible with VIERA Link.

■ **Limitations of image output**

- When using SDIOUT output, side LCD and EVF cannot be operated simultaneously. In order to perform simultaneous operation, set the SDI OUT on the settings menu AV IN/OUT SETUP to OFF. When the EVF MODE on the settings menu DISPLAY SETUP is set to AUTO, EVF disappears upon opening/closing of the LCD.
- No HDMI output is performed when REC FORMAT is set to 1080/24p and SDI 24Ps is set to ON.
- When SDI&HDMI OUT SEL is set to DOWNCONV, SIDE CROP is disabled in the DOWNCON MODE settings, and SQUEEZE is enabled automatically.
- Some displays, such as time code display and audio level meter display may not be visible on the videos output from the VIDEO OUT terminal.

Nonlinear editing

Non-linear editing of video data on SD Memory Cards can be performed by connecting the camera via the USB connection cable to a computer for editing. (As for connection, refer to page 42) Use a sufficiently charged battery or the AC adaptor.

The following conditions are necessary for USB connection.

- PC with Windows XP, Windows Vista, or Windows 7; or Macintosh with Intel CPU (Intel Mac)
- USB 2.0 (High Speed, Mass Storage Class) compatibility (not compatible with USB 1.1)
- Only connect to one computer at a time.
- Camera cannot be operated if a hub or other device is connected between the camera and computer.

1 Insert the SD Memory Card, and move the POWER switch to ON.

2 Connect the camera to the computer with the USB connection cable.

Turn the computer's power on before connecting.

3 Select 'PC'

Dubbing can be performed to a Blu-ray Disc Recorder, etc. by selecting 'RECORDER'.

4 Perform non-linear editing on the computer.

The contents of the SD Memory Card will appear as a removable disk icon within My Computer or the desktop on the computer screen. (Page 73)
(Example) Windows



Removable disk (E:)

(Example) Macintosh



NO NAME

- When copying files from the camera to a computer, be careful to ensure that files are not accidentally overwritten.
- For more details, please refer to your computer editing software's operating instructions.
- When changing cards, always ensure that the access lamp is not flashing and that the card is not currently being accessed.
- Camera functions cannot be used when the camera is connected to a computer.
- Always perform "safe hardware removal" when disconnecting the cable.
- The data on the SD Memory Card cannot be accessed when the SD Memory Card slot cover is open.

5 Turn the camera's power off.

- If the camera cannot be correctly recognized by the computer, this may be able to be remedied by one of the following methods.
 - Turn the power of the camera and the computer off and back on again.
 - Remove the SD Memory Card from the camera and reinsert it.
 - Connect to a different USB terminal on the computer.
 - If you are using an SDXC memory card, some personal computers may not recognize the data. Make sure your personal computer supports SDXC cards.
-

Screen displays

Regular displays

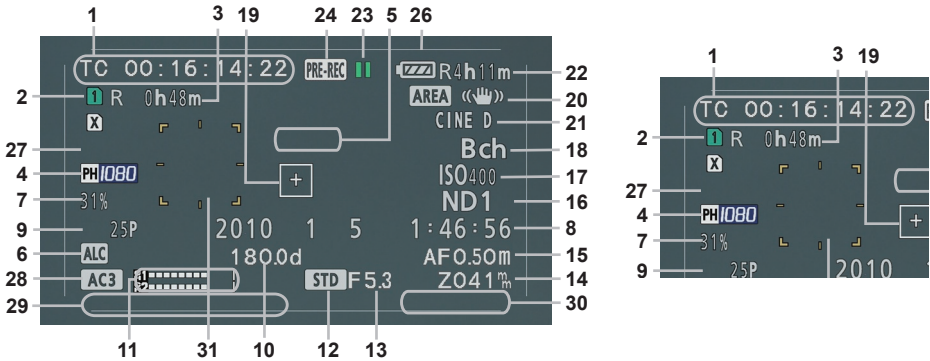

1 Time code display

Each time you press the COUNTER button, the display switches over to the following data (or no indication).

COUNTER:

Counter value

Displayed when TOTAL is selected from the REC COUNTER item in the DISPLAY SETUP screen of MENU settings.

CLIP:

CLIP counter value for respective clip

Displayed when REC COUNTER item on settings menu DISPLAY SETUP screen is set to CLIP.

- During playback, the time code display is automatically set to CLIP, and the time code is counted from a value of 0:00:00 for each clip.

TC:

Time code value.

When the time code value could not be read correctly from the SD Memory Card, [TC*] is displayed.

UB:

User information

When user information could not be read correctly from the SD Memory Card, [UB*] is displayed.

2 Media information display

Displays basic information about inserted SD memory cards. Information regarding slot 1 is displayed above, and information regarding slot 2 is displayed below.

: Recording possible (White)

- Displayed in green if used for recording.

: Card is write-protected

: Recording not possible

: Card is full

- Recording may be possible in some cases even when this icon is displayed.

- Depending on the memory size and type of the SD Memory Card used, the icon may not be displayed even when the card's memory becomes full during shooting, and the shooting is stopped.

: Playback-only

- SD Memory Cards already containing 1,000 or more clips may be used for playback only.

: Accessing card

: No card inserted

- Flashes red.

3 Media capacity display

Displays remaining capacity for recording frame rate set in the REC FORMAT item on the settings menu SCENE FILE screen. Not displayed during PB mode.

- Time displayed is a guideline only.
- The remaining capacity of the slot 2 is also displayed here.

4 Recording format display (Page 51)

5 Information display

Following information is displayed depending on the situation.

- Performance of the auto white balance or the auto black balance
- Warning (Page 48)
- The ND filter recommended under the prevailing shooting conditions is displayed.

Screen displays (continued)

- The AWB error message (LOW LIGHT / LEVEL OVER) is displayed. (Page E-42 of Vol.1)
- The functions allocated to the USER buttons are displayed while you hold down the DISP/MODE CHK button.

6 Microphone level automatic control display

Appears when in the setup menus, RECORDING SETUP screen, MIC ALC, you have selected "ON".

7 Marker luminance display

When markers are displayed, the brightness level around the center of the screen is indicated as 0% to 99%. "99%↑" appears if the percentage is over 99.

- When the AREA Y-GET function is operating, the brightness level around the center of the AREA frame is displayed.

8 Date and time display

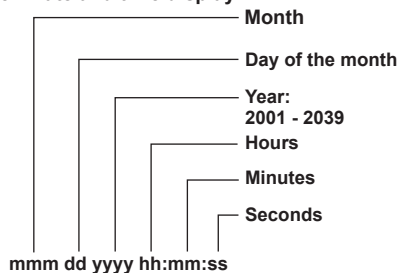

9 Frame rate display

Displays recording frame rate.
Not displayed when set to 1080/60i.

10 Shutter speed display

The shutter speed is displayed here.

11 Audio level meter display (Page 18)

12 Auto iris control display

STD: Standard auto-iris control
SPOT: Auto iris control for spotlight
BACK: Auto iris control for backlight compensation

13 Iris display

Displays F value. The STEP of the display value differs depending on the lens.

14 Zoom position display

The zoom position is displayed with Z00 (maximum wide-angle) - Z99 (maximum zoom). The unit can be switched to mm in the ZOOM & FOCUS item of the setting menu DISPLAY SETUP screen.
The focus position display does not move linearly.

15 Focus control information display

Displays the focus control information with 99 - 00. In the auto focus mode, AF appears. In the manual focus mode, MF appears.
The units can be switched between feet and m in the ZOOM & FOCUS item of the setting menu DISPLAY SETUP screen.
The STEP of the display value differs depending on the lens.

16 ND filter display

ND filter selected is displayed.

17 Gain display

Displays the gain value of the image amplifier configured. (During the auto mode, AGC is displayed.)

18 AWB information display

Displays the information of white balance.
ATW: When ATW is set
P3.2K/P5.6K/VAR: In the case of preset
Ach/Bch: In the case of A/B
LOCK: When ATW is locked

19 Marker display

During shooting, pressing the ZEBRA button once or twice will display the marker.

20 Optical Image Stabilizer (OIS) display

Displayed when Optical Image Stabilizer is ON.

21 Scene filename display (Page 19)

22 Remaining battery capacity display

When using Panasonic-manufactured batteries compatible with this product, the remaining battery capacity is displayed in minutes. Time remaining will be displayed after a brief pause.

- The battery display will change



as battery capacity decreases. The 25% icon will be displayed in red when less than 3 minutes are remaining, and the empty battery icon will flash when the battery is empty.

(Continued on the next page)

- Remaining battery capacity may not be displayed correctly when using in high or low temperatures, or when the battery has not been used for a long period of time. To ensure that remaining battery capacity is displayed correctly, use the battery completely from a fully-charged state, and charge the battery again. (Remaining battery capacity may still not be displayed correctly if the battery has been used for long periods in high or low temperatures, or if the battery has been recharged a large number of times.)
- The remaining battery capacity display is a guideline and may change according to usage conditions.
- The remaining battery capacity display will momentarily disappear when switching between modes, when conducting REC CHECK operations or when changing the LCD brightness since the capacity is recalculated at these times.
- Not displayed when using AC adaptor.

23 Operation status display

- (Red) : Recording
- (Green): Playback paused
- ▷ : Playback
- (White): Playback paused
- INDEX [□□]: Playback paused at INDEX position
- ▷ (◁□□): Frame-by-frame playback (Frame-by-frame reverse playback)
- ▷▷ (◁◁): Skip (reverse skip)
- ▷▷ (◁◁): Fast forward/fast playback (Rewind/fast reverse playback)
- ▷ (◁): Paused in final scene (paused in initial scene)

Self-portrait recording display

- No display: Cannot record (no card, etc.)
- : Recording in progress, during transition to the recording pause mode
- : Recording paused (recording standby)
- ! : Warning display

24 Recording function display

- PRE-REC :When pre-rec mode is ON
- ↔ :In interval REC mode

25 Monitor audio level meter

When you press the AUDIO MON/ADV button, the sound volume output from the built-in speaker and headphone jack is displayed.

26 Safety zone

The range of the zone is indicated by the SAFETY ZONE item (Page 59) on the DISPLAY SETUP screen.

- 90%: Range that can be displayed on an ordinary home-use TV set.
- 4:3: Range cropped to 4:3
- 14:9: Range in between 16:9 and 4:3
- 2.35:1: Cinema scope range
- 2:1 : 2:1: Scope range
- 1.85:1: American visa range
- GRID: Horizontal/vertical grid lines

27 Metadata recording information

- META: When metadata recording is ON
- No display: When metadata recording is OFF

28 Recording audio type display

- LPCM: When audio LPCM recording
- AC3 : When audio AC3 recording

29 FOCUS_BAR display

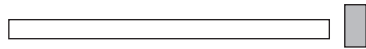

Displays the above items in the bottom left of the LCD/EVF. Digitizes and displays high-frequency component volumes for videos.

White bar: focus bar display
Green line: peak display

30 IRIS METER display



Displays the above items in the bottom right of the LCD/EVF.

- Center: Indicates the normal light intensity.
- Right: Indicates high-light intensity.
- Left: Indicates low-light intensity.
- Green dots on display: Indicate the compensation amount during AUTO IRIS.

31 AREA frame display

Displays the range of the AREA function.

Main warning displays

The main warning displays appearing on the LCD monitor or viewfinder are listed below. If a warning display is not listed, check carefully the message displayed.

■ C

CANNOT BE USED DUE TO INCOMPATIBLE DATA.

No use is possible because the standard for the data is different.

CANNOT DELETE.

Clip cannot be deleted.

CANNOT DELETE WITH THIS BUTTON

Clip cannot be deleted.

CANNOT PLAY.

No playback is possible.

CANNOT PLAY WITH THIS BUTTON

No playback is possible.

CANNOT RECORD PH MODE AND HA MODE INTO THIS CARD.

This card cannot be recorded to in PH mode or HA mode.

CANNOT RECORD.

THE NUMBER OF CLIPS HAS EXCEEDED THE MAXIMUM LIMIT.

The maximum number of clips has been reached and no further clips can be recorded.

CANNOT SET THE NUMBER OF INDEXES HAS EXCEEDED THE MAXIMUM LIMIT.

No further indexes can be set because the number of indexes will exceed the maximum limit.

CANNOT SET PRE-REC, CARD CAPACITY TOO LOW.

PRE-REC cannot be set as the remaining card capacity is low.

CARD DOOR OPENED.

The card door is open.

CARD ERROR.

PLEASE REFORMAT.

Formatting has failed. The card needs to be reformatted.

CARD FULL.

The card is full.

CHECK CARD.

Please check the card.

If an SD memory card that has been used before in another device or personal computer is used for the first time in this camera-recorder, CHECK CARD is displayed, and all operations may be disabled. In such a case, perform the following:

- ① Remove the SD memory card from the unit and insert it again. (Page E-38 of Vol.1)
The unit recognizes the SD memory card and cancels the CHECK CARD display.
- ② If the CHECK CARD display is not canceled even after removing and inserting the SD memory card several times, check the contents of the card on a personal computer, and erase the entire data.
- ③ Format the SD memory card in the unit. (Page E-36 of Vol.1)

If the data on the card cannot be either read or erased on a personal computer, the SD memory card may be corrupted. Use another SD memory card.

CHECK USB CABLE.

Please connect the camera-recorder to a PC.

CONTROL DATA ERROR HAS BEEN DETECTED.

An error has been detected in the control information.

■ D

DISCONNECT USB CABLE.

When switching from one mode to another, disconnect the USB connection cable.

■ I

INCOMPATIBLE CARD. PLEASE CHECK CARD.

This card may have been formatted in a format with different system frequency. Check the card.

(Continued on the next page)

N _____**NO CARD**

No card is inserted.

NOW ACCESSING.**PLEASE DO NOT REMOVE CARD.**

Card is currently being accessed. Please do not remove the card.

R _____**REC STOPPED.****NOW WRITING.**

Video recording has been stopped. Data is now being written to the card.

REPAIR CLIP?

Do you wish to repair clips now?

S _____**SD CARD FORMAT?****YES NO**

Do you wish to format the SD Memory Card now? Yes/No

SET DATE AND TIME

Set the date and time.

T _____**THE CLIP IS PROTECTED.****PLEASE CANCEL PROTECTION.**

The clip is protected. Please cancel the protection.

**THE RECORDING IS STOPPED
(OVER THE LIMITATION)**

Recording will stop. (Continuous recording for 12 hours)

THE TC MODE IS CHANGED TO "NDF"

NDF is selected as the TC MODE setting.

THIS BATTERY CANNOT BE USED.

This battery cannot be used.

**THIS CARD CANNOT RECORD IN VIDEO
MODE.**

The card cannot be used for video recording.

THUMBNAIL DATA ERROR IS DETECTED.

An error has been detected in the thumbnail information.

U _____**UNABLE TO FORMAT.**

The card cannot be formatted.

W _____**WRITE PROTECT**

The card is write-protected.

Error displays

The following messages are displayed when an error has occurred in the camera or the SD Memory Card. If the problem is not solved by switching the power off and back on again, either change the card in accordance with the instructions displayed, or consult the place of purchase.

C _____**CANNOT RECORD**

Displayed when an error has occurred during recording.

R _____**REC WARNING**

Displayed when an error has occurred during recording. Start the recording again. If the message appears again, please consult the place of purchase.

- Please switch the power off if the message continues to appear.
- Please try inserting a different card if the message appears again after restarting recording.

S _____**SYSTEM ERROR****TURN POWER OFF**

Displayed when an error has occurred in the system. Switch the power off and back on again.

- If this error is displayed when accessing the SD Memory Card, such as when deleting a clip, the SD Memory Card may be damaged. Please replace it with a new SD Memory Card.
- If this error is displayed when repairing the SD Memory Card, please use the AVCCAM Restorer content repair software (Page E-38 of Vol.1).

W _____**WARNING**

Displayed when an error has occurred with the camera itself. Start the recording again.
FOCUS NG (error with focus operation)
PSD NG (error with jitter detection)

Screen displays (continued)

Setting the DISPLAY items

Display the following items on the viewfinder and LCD monitor by pressing the DISP/MODE CHK button or by configuring OTHER DISPLAY of the DISPLAY SETUP screen of the setup menus. (Page 60)

Displays	MODE CHK (Hold down DISP/ MODE CHK button)	DISPLAY	OTHER DISPLAY settings		
			ALL	PARTIAL	OFF
1 Time code display	✓	—	—	—	—
2 Media information display	✓	✓	—	—	—
3 Media capacity display	✓	✓	—	—	—
4 Recording format display	✓	✓	✓	x	x
5 Information display	—	—	—	—	—
6 Microphone level automatic control display	✓	✓	✓	x	x
7 Date and time display	✓	✓*4	—	—	—
8 Frame rate display	✓	✓	✓*1	x	x
9 Shutter speed display	✓	✓	✓	✓	x
10 Audio level meter display	✓	✓	—	—	—
11 Auto iris control display	✓	✓	✓	✓	x
12 Iris display	✓	✓	✓	✓	x
13 Zoom position display	✓	✓	—	—	—
14 Focus control information display	✓	✓	—	—	—
15 ND filter display	✓	✓	✓	x	x
16 Gain display	✓	✓	✓	✓*2	x
17 AWB information display	✓	✓	✓	✓*3	x
18 Marker display	—	—	—	—	—
19 Optical Image Stabilizer display	✓	✓	✓	✓	x
20 Scene filename display	✓	✓	✓	x	x
21 Remaining battery capacity display	✓	✓	—	—	—
22 Monitor audio level display	—	—	—	—	—

✓: Displayed

x: Not displayed

—: Displayed depending on other settings

The item in ✓ in the MODE CHECK space appears when you press and hold the DISP/MODE CHK button.

The item in ✓ in the DISPLAY space disappears when you press the DISP/MODE CHK button.

*1 Not displayed when frame rate is set to 60i/50i.

*2 0 dB is not displayed.

*3 Only preset 3.2K, 5.6K and VAR are displayed.

*4 If the date and time display appear simultaneously, they may not be removed even by pressing the DISP/MODE CHK button.

Setup menu list

SCENE FILE screen

Item	Display mode	Description of settings
SCENE SELECT	(Camera)	Selects the settings (SCENE FILES) according to the variety of shooting circumstances. You can read, save, and initialize these settings from MENU - SCENE FILE - LOAD / SAVE / INIT. F1, F2, F3, F4, F5, F6
OPERATION TYPE	(Camera)	Switches the shutter and frame rate operation to video type or film type. FILM CAM: VFR operation is enabled. SLOW shutter speeds are disabled. SYNCROSCAN is displayed as an angle. Gain is displayed as ISO. VIDEO CAM: VFR operation is disabled. SLOW shutter speeds are enabled. SYNCROSCAN is displayed as 1/n. Gain is displayed as dB.
REC FORMAT	(Camera)	Selects the recording format. When SYSTEM FREQ = 59.94 Hz PH 1080/24P and PH 720/24P represent native recording. PH 1080/60i, PH 1080/30P, PH 1080/24P, PH 720/60P, PH 720/30P, PH 720/24P, HA 1080/60i, HE 1080/60i When SYSTEM FREQ = 50 Hz PH 1080/50i, PH 1080/25P, PH 720/50P, PH 720/25P, HA 1080/50i, HE 1080/50i
VFR MODE	(Camera)	ON: Enables the VFR (Variable Frame Rate) mode. OFF: Disables the VFR mode. Functions only when REC FORMAT is set to 1080/24P, 1080/30P, or 1080/25P. Functions only when OPERATION TYPE = FILM CAM Does not function when SDI 24PsF is set to ON. Audio cannot be recorded when VFR MODE = ON.
FRAME RATE	(Camera)	Sets the FRAME RATE. Operates only when OPERATION TYPE = FILM CAM. You can make the settings from SHUTR/F.RATE on the rear side of the camera also. When SYSTEM FREQ = 59.94 Hz 12/15/18/20/21/22/24/25/26/27/28/30/32/34/36/40/44/48/54/60 When SYSTEM FREQ = 50 Hz 12/15/18/20/21/22/23/24/25/26/27/28/30/32/34/37/42/45/48/50
SYNCRO SCAN	(Camera)	Adjusts the synchro scan shutter speed used for shooting images on a TV screen, etc. Holding the OPERATION lever toward the ◀ or ▶ will cause the values to change at a faster rate. When OPERATION TYPE = VIDEO CAM and SYSTEM FREQ = 59.94 Hz • 60P/60i: 1/60.0...1/250.6 • 30P: 1/30.0...1/48.0...1/250.6 • 24P: 1/24.0...1/48.0...1/250.6 When OPERATION TYPE = VIDEO CAM and SYSTEM FREQ = 59.94 Hz • 50P/50i: 1/50.0...1/250.0 • 25P: 1/25.0...1/48.0...1/250.0 When OPERATION TYPE = FILM CAM, "deg (angle)" Display 10.0d...172.8d...180.0d...360.0d (0.5d/div)

___ indicates the factory setting.

Setup menu list (continued)

SCENE FILE screen (continued)

Item	Display mode	Description of settings
DETAIL LEVEL	(Camera)	Adjusts the level of the image outline correction (in the horizontal and vertical directions). -7...0...+7
V DETAIL LEVEL	(Camera)	Adjusts the level of outline correction in the vertical direction. -7...0...+7
DETAIL CORING	(Camera)	Adjusts the level of noise reduction of the detail signal. Set to – for a clearer image. Noise increases slightly. Set to + to reduce noise. -7...0...+7
CHROMA LEVEL	(Camera)	Adjusts the chroma level. -7...0...+7
CHROMA PHASE	(Camera)	Adjusts the chroma level. -7...0...+7
COLOR TEMP Ach	(Camera)	Make fine adjustments to the color temperature (after white balance Ach adjustment). -7...0...+7
COLOR TEMP Bch	(Camera)	Make fine adjustments to the color temperature (after white balance Bch adjustment). -7...0...+7
MASTER PED	(Camera)	Adjusts the master pedestal (black level of the image) as the basis for images. -15...0...+15
A.IRIS LEVEL	(Camera)	Sets the desired AUTO IRIS level. -6...0...+6
DRS	(Camera)	Selects the DRS (Dynamic Range Stretcher) function. It enables the dynamic range to be expanded by compressing the level of the video signals in the high-brightness areas where overexposure results during normal shooting. OFF, 1, 2, 3 <ul style="list-style-type: none"> • The higher the number of the setting, the higher the compression level of the high-brightness areas. • The higher the number of the setting, the greater the interference in darker areas.
GAMMA	(Camera)	Selects the gamma curves. HD NORM: This gamma setting is suitable for HD shooting. LOW: Makes a mellow image using the gamma curve that has a gentle incline in low-brightness curve. The contrast sharpens. SD NORM: This is the normal video setting carried over from the DVX100 series. HIGH: Expands the tone of dark parts and makes a brighter image using the gamma curve that has a sharp incline in low-brightness curve. The contrast softens. B.PRESS: Makes the contrast sharper than LOW. CINE-LIKE D: Uses a gamma curve designed to create cinema-like images. CINE-LIKE V: Uses a gamma curve designed to create cinema-like images with emphasized contrast. <ul style="list-style-type: none"> • When you select CINE-LIKE gamma, we recommend setting the lens aperture lower than normal image level (approximately 1/2) for optimal results.
KNEE	(Camera)	To avoid overexposure, select the compression level (knee point) of the high intensity video signals received through the image pickup device. AUTO: Sets the level automatically according to the received signals. LOW: Low setting (Compression starts at approx. 80%) MID: Medium setting (Compression starts at approx. 90%) HIGH: High setting (Compression starts at approx. 100%) <ul style="list-style-type: none"> • Not available when a DRS value is set, or when GAMMA is set to CINE-LIKE.

_____ indicates the factory setting.

SCENE FILE screen (continued)

Item	Display mode	Description of settings
MATRIX	(Camera)	Selects the MATRIX table suitable for the desired color expression during shooting. NORM1: Suitable for shooting in the open air or under a halogen lamp. NORM2: Suitable for brighter colors than the NORM1 mode. FLUO: Suitable for shooting under fluorescent lights indoors. CINE-LIKE: Suitable for cinema-like images.
SKIN TONE DTL	(Camera)	Switches skin tone details ON or OFF. Select ON to reduce the skin tone details and soften the skin tone. ON, OFF
B/W MODE	(Camera)	Selects the black and white shooting function. All recorded and output video signals are converted to black and white. Color temperature adjustment modes, such as AWB, operate even when the B/W MODE is ON and affect the black and white images. It is recommended that you set the B/W MODE to ON after adjusting and checking the white balance when the B/W MODE is OFF. ON, OFF
CARD READ	(Camera)	Reads scene files from the SD Memory Card. Slot1: Reads scene files (all scenes from F1 to F6) saved on the SD Memory Card of Slot 1 after selecting the setting values. Slot2: Reads scene files (all scenes from F1 to F6) saved on the SD Memory Card of Slot 2 after selecting the setting values. NO: Returns to the previous screen.
CARD WRITE	(Camera)	Saves scene files on the SD Memory Card. Slot1: Saves the setting values of scene files (all scenes from F1 to F6) on the SD Memory Card of Slot 1. Slot2: Saves the setting values of scene files (all scenes from F1 to F6) on the SD Memory Card of Slot 2. NO: Returns to the previous screen.
LOAD/SAVE/INIT	(Camera)	LOAD: Loads the scene file settings saved by this camera. SAVE: Saves the updated scene file settings. INITIALIZE: Returns the settings of the scene file selected from the SCENE FILE item to factory settings. NO: Returns to the previous screen.
NAME EDIT	(Camera)	Edits the name of the scene file selected from the MENU/SCENE FILE/SCENE SELECT. YES, NO

___ indicates the factory setting.

SW MODE screen

Item	Display mode	Description of settings
FUNCTION KNOB	(Camera)	Sets the function assigned to the AREA operation of the FUNCTION KNOB. INH: No function is assigned. FOCUS: AUTO FOCUS / FOCUS BAR function IRIS: AUTO IRIS / IRIS METER function YGET: YGET (Luminance measurement) function FOCUS/IRIS: Simultaneous operation of FOCUS and IRIS described above FOCUS/YGET: Simultaneous operation of FOCUS and YGET described above

___ indicates the factory setting.

Setup menu list (continued)

SW MODE screen (continued)

Item	Display mode	Description of settings
LOW GAIN	(Camera)	Sets the gain value assigned to the L position of the GAIN switch. When OPERATION TYPE = FILM CAM ISO200, ISO250, ISO320, <u>ISO400</u>, ISO500, ISO640, ISO800, ISO1000, ISO1250, ISO1600, ISO2000, ISO2500, ISO3200 When OPERATION TYPE = VIDEO CAM -6dB, -3dB, <u>0dB</u>, 3dB, 6dB, 9dB, 12dB, 15dB, 18dB
MID GAIN	(Camera)	Sets the gain value assigned to the M position of the GAIN switch. When OPERATION TYPE = FILM CAM ISO200, ISO250, ISO320, ISO400, ISO500, ISO640, <u>ISO800</u>, ISO1000, ISO1250, ISO1600, ISO2000, ISO2500, ISO3200 When OPERATION TYPE = VIDEO CAM -6dB, -3dB, <u>0dB</u>, 3dB, 6dB, 9dB, 12dB, 15dB, 18dB
HIGH GAIN	(Camera)	Sets the gain value assigned to the H position of the GAIN switch. When OPERATION TYPE = FILM CAM ISO200, ISO250, ISO320, ISO400, ISO500, ISO640, ISO800, ISO1000, ISO1250, ISO1600, ISO2000, ISO2500, ISO3200 When OPERATION TYPE = VIDEO CAM -6dB, -3dB, <u>0dB</u>, 3dB, 6dB, 9dB, 12dB, 15dB, 18dB
ATW	(Camera)	Sets the operation of the ATW (Auto Tracking White) function assigned to the WHITE BAL switch. When the ATW function is allocated to the USER button, the operation remains effective. Ach: Activates the ATW function when the WHITE BAL switch is set to A. Bch: Activates the ATW function when the WHITE BAL switch is set to B. PRST: Activates the ATW function when the WHITE BAL switch is set to PRST. OFF: Deactivates the ATW function.
IRIS DIAL	(Camera) (PB)	Sets the rotation direction and aperture control of the IRIS dial. (In MANUAL IRIS mode) DOWN OPEN: The aperture opens when the IRIS dial is turned downward. UP OPEN: The aperture opens when the IRIS dial is turned upward.

_____ indicates the factory setting.

SW MODE screen (continued)

Item	Display mode	Description of settings
USER1 SW	(Camera) (PB)	<p>Sets the function assigned to the USER1 button.</p> <p>INH: No function is assigned</p> <p>REC CHECK: Performs recording check.</p> <p>FACE DETECT: This is the face detection function. Performs the AUTO IRIS / AUTO FOCUS operation centering around the detected face. Enabled when both focus control and iris control are set to auto.</p> <p>FA: Displays the edges in red. (Only for LCD/EVF) During operation, the LCD/EVF borders are displayed in red.</p> <p>CAPTURE: Records still images. Does not operate during movie recording and when the PRE REC function is in use.</p> <p>ATW: Switches the ATW function ON or OFF.</p> <p>ATW LOCK: Fixes the white balance value when the button is pressed during ATW. Press again to perform ATW.</p> <p>SHOT MARK: Shot mark recording. (Page 13) Takes effect during recording, thumbnail display, and clip display.</p> <p>INDEX: Index recording (Page 13) Takes effect during recording.</p> <p>LAST CLIP: Deletes the last recorded clip. (Page 13)</p> <ul style="list-style-type: none"> • After recording, clips cannot be deleted by switching to PB or PC mode, by changing the recording format, or by turning off the camera. <p>BACKLIGHT: Auto iris control for the backlight compensation.</p> <p>SPOTLIGHT: Switches auto iris control ON or OFF for the spotlight.</p> <p>BLACKFADE: Blackfade (Page 11)</p> <p>WHITEFADE: Whitefade (Page 11)</p>
USER2 SW	(Camera) (PB)	<p>Assign a function to the USER2 button.</p> <p>The setting contents are the same as USER1.</p> <p>ATW LOCK</p>
USER3 SW	(Camera) (PB)	<p>Assign a function to the USER3 button.</p> <p>The setting contents are the same as USER1.</p> <p>REC CHECK</p>
WFM	(Camera)	<p>Switches the waveform display that appears when the WFM button is pressed.</p> <p>WAVE: Displays as a waveform.</p> <p>VECTOR: Displays as a vector.</p> <p>WAVE/VECTOR: Each time the button is pressed, the setting changes in the following order: OFF → WAVE → VECTOR → OFF.</p>
S/S SW INH	(Camera)	<p>1: Disables the START/STOP1 SW.</p> <p>2: Disables the START/STOP2 SW.</p> <p>NO: Does not disable any switch. Use to prevent erroneous operation of the unnecessary START/STOP SW.</p>
FACE FRAMING	(Camera)	<p>Frames the faces detected during operation of the FACE DETECT function with the USER SW.</p> <p>The maximum number of detected frames is 15, and faces bigger and closer to the center of the screen are given priority.</p> <p>OFF: Frames are not displayed.</p> <p>PRIMARY: Only the high-priority frames are displayed.</p> <p>ALL: Cannot be set when you are using INTERVAL REC.</p>

___ indicates the factory setting.

Setup menu list (continued)

RECORDING SETUP screen

Item	Display mode	Description of settings
PREREC MODE	(Camera)	Sets PRE RECORDING to ON or OFF. ON: Enables PRE REC function. OFF: Disables PRE REC function. <ul style="list-style-type: none"> • TCG is set to FREE RUN. • Cannot be set when you are using INTERVAL REC.
INTERVAL REC	(Camera)	Scenes moving slowly over a long period of time are recorded as short movies by providing a recording interval. One frame is recorded in each recording time period that has been set, and 24 frames (PAL 25 frames) form a one-second video. When you set INTERVAL REC, the following items are set automatically: PH Mode 1080/24P (When SYSTEM FREQ = 59.94) 1080/25P (When SYSTEM FREQ = 50) <ul style="list-style-type: none"> • TC RECRUN Fixed to NDF • Audio recording is not performed. OFF, 1SECOND, 10SECONDS, 30SECONDS, 1MINUTE, 2MINUTES
RELAY REC	(Camera)	ON: Relay recording performed. When the SD card used for recording has no remaining space, recording continues in another SD card if an SD card that can be used for recording is inserted in another SD card slot. OFF: Relay recording not performed. Recording stops when the target SD card has no remaining space.
PH AUDIO MODE	(Camera)	Selects the format of audio recording when REC FORMAT = PH. LPCM: Recording is performed in uncompressed LPCM. AC3: Recording is performed in Dolby AC3 format. <ul style="list-style-type: none"> • Fixed to AC3 for other than the PH mode. • If LPCM is set, playback is not possible in our previous models, such as AG-HMR10.
MIC ALC	(Camera)	ON: Enables mic level auto control. OFF: Disables mic level auto control. Audio distortion can be reduced at high input levels. To adjust the recording level of audio signals (regardless of this setting), use the AUDIO control knobs.
MIC GAIN1	(Camera)	Sets the input level of the external microphone connected to the INPUT 1 terminal. -50dB, -60dB
MIC GAIN2	(Camera)	Sets the input level of the external microphone connected to the INPUT 2 terminal. -50dB, -60dB

___ indicates the factory setting.

TC/UB SETUP screen

Item	Display mode	Description of settings
TC MODE	(Camera)	<p>Selects the correction mode of the internal time code when the time code of the internal time code generator is recorded.</p> <p>DF: Uses the drop frame mode.</p> <p>NDF: Uses the non-drop frame mode.</p> <ul style="list-style-type: none"> TC MODE is automatically set to NDF when you set recording frame rate of recording format to 24P. Takes effect only when SYSTEM FREQ = 59.94 Hz. PH 1080/24P and PH 720/24P represent native recording.
TCG	(Camera)	<p>Sets the mode in which you advance the internal time code generator.</p> <p>FREE RUN: The time code is advanced regardless of the operation mode. A slight time error may occur when switching to PB mode if the frame rate is set to 24P.</p> <p>REC RUN: The time code is advanced only when recording.</p>
TC PRESET	(Camera)	<p>Sets the initial time code.</p> <p>Set the frame value to 0 or a multiple of 4 when you set recording frame rate of recording format to 24P. If any other value is set, the recorded time code will mismatch.</p> <p>YES, NO</p>
UB PRESET	(Camera)	<p>Sets the user information.</p> <p>YES, NO</p>
EXT TC LINK	(Camera)	<p>Synchronizes the initial time code value during multi-camera shooting. (SLAVE camera time codes are synchronized to the master internal TCG value.)</p> <p>MASTER: Sets the mode to master mode.</p> <p>SLAVE: Sets the mode to slave mode. When the COUNTER RESET/TC SET button is pressed, input time codes are synchronized to the internal TCG.</p> <p>NO: Returns to the previous screen.</p> <ul style="list-style-type: none"> MASTER and SLAVE mode settings are in effect only when this menu is open. When the menu is closed, EXT TC LINK is automatically canceled.

___ indicates the factory setting.

Setup menu list (continued)

AV IN/OUT SETUP screen

Item	Display mode	Description of settings
SDI & HDMI OUT SEL	(Camera) (PB)	Sets the output video format of the SDI&HDMI OUT terminal. 1080i/720P: Output at the resolution set in REC FORMAT. DOWNCONV: SDI is output at 480i, while HDMI is output at 480p. (When SYSTEM FREQ = 59.94) SDI is output at 576i, while HDMI is output at 576p. (When SYSTEM FREQ = 50)
SDI OUT	(Camera) (PB)	Sets the video output from the SDI terminal. ON: Video is output from SDI OUT. At this point, simultaneous LCD display and EVF display is not supported. Close the LCD monitor when using EVF. OFF: No video is output from SDI OUT.
SDI 24PsF	(Camera) (PB)	Sets the video format output from SDI OUT to 24PsF. ON: Operates only when REC FORMAT = 1080 24p. Does not operate during VFR operation (when the recording format is other than 24p). The HDMI output stops during 24PsF output. OFF: SDI output is in the 1080 60i format. • This item is not available when SYSTEM FREQ = 50Hz.
SDI EDH	(Camera) (PB)	Sets superimposition of EDH on to the SDI output during SD SDI output. ON: Superimposes EDH. OFF: Does not superimpose EDH.
DOWNCON MODE	(Camera) (PB)	Switches down-conversion output mode. SIDE CROP: Side-crop mode (Crops the left and right edges.) Images may extend beyond the boundaries of the screen and be partially unable to be seen when outputting from the +H227A/V terminal or SDI OUT terminal (during DOWNCONV), or the HDMI terminal (during DOWNCONV). LETTER BOX: Letterbox mode (Adds black bands at the top and bottom of the image). SQUEEZE: Squeeze mode (Squeezes images horizontally).
HP MODE	(Camera)	Selects the sound heard from the headphones. LIVE: The sound input from the microphone is output as is. This setting is selected when delays in the sound are annoying. RECORDING: The sound in the status to be recorded (the sound synchronized with the images) is output.
TEST TONE	(Camera)	Sets test tone output to channels 1, 2, 3, and 4 when BARS setting is ON. ON: Outputs the test tone. OFF: Does not output the test tone.
VIDEO SETUP	(Camera) (PB)	Sets the setup level of video signals. 0%: VIDEO OUT terminal output and recording setup levels will both be set to 0%. 7.5%A: VIDEO OUT terminal output setup level will be set to 7.5%, while recording setup level will be set to 0%. • This item is not available when SYSTEM FREQ = 50Hz.
AUDIO OUT	(Camera) (PB)	Sets the audio signals to output from the AUDIO OUT terminal (A/V OUT). CH1/CH2: CH1 terminal = CH1 signals, CH2 terminal = CH2 signals CH1: CH1 terminal = CH1 signals, CH2 terminal = CH1 signals CH2: CH1 terminal = CH2 signals, CH2 terminal = CH2 signals • When an SD Memory Card containing 5.1 channel content recorded on another equipment is played back on the camera, it is down-mixed to 2 channels when output through the AUDIO OUT and headphone terminals.

_____ indicates the factory setting.

DISPLAY SETUP screen

Item	Display mode	Description of settings
ZEBRA DETECT 1	(Camera)	Selects the brightness level of the right-leaning zebra patterns on the screen. 50%, 55%, 60%, 65%, 70%, 75%, 80%, 85%, 90%, 95%, 100%, 105%
ZEBRA DETECT 2	(Camera)	Selects the brightness level of the left-leaning zebra patterns on the screen. 50%, 55%, 60%, 65%, 70%, 75%, 80%, 85%, 90%, 95%, 100%, 105%
Y GET MARKER	(Camera)	Sets the display of the marker used for displaying the luminance level to ON or OFF. Select ON to display the marker by pressing the ZEBRA button. ON, OFF
SAFETY ZONE	(Camera)	Sets the SAFETY ZONE. 90%: 90% display at 16:9 4:3: 100% display at 4:3 14:9: 100% display at 14:9 1.85:1: 100% display t 1.85:1 2:1: 100% display at 2:1 2.35:1: 2.35:1 cinemascope display GRID: 16:9 angular field of view with nine grid lines OFF: The SAFETY ZONE is not displayed.
CENTER MARKER	(Camera)	Sets the CENTER MARKER. Select ON to display the CENTER MARKER. ON, OFF
FOCUS BAR	(Camera)	Sets the FOCUS ASSIST bar display to ON or OFF. Select ON to display the FOCUS ASSIST bar. ON, OFF
REC COUNTER	(Camera)	Selects counter operation during recording. TOTAL: The count continues to increase until the COUNTER RESET button is pressed to reset it. CLIP: Resets the counter at start of recording and counts the time of each recording session. • In the PB mode, the operation is always in CLIP mode.
VIDEO OUT OSD	(Camera) (PB)	Select ON to output the information displayed on the screen together with the signals from the VIDEO OUT jack. ON, OFF • Some items are not output from the A/V terminal.
IRIS METER	(Camera)	Sets the display of the IRIS METER. ON: As regards the brightness of the image, displays the difference with respect to the optimum value judged by the camera. The bar appears on the right: The image is too bright. The bar appears on the left:: The image is too dark. OFF: The IRIS METER is not displayed.
DATE/TIME	(Camera) (PB)	Sets whether to display the date and time on the screen and whether to output from the VIDEO OUT jack. OFF: The date and time are not displayed. TIME: The time is displayed. DATE: The date is displayed. TIME & DATE: The date and time are displayed.
DATE FORMAT	(Camera) (PB)	Changes the style of displaying the year, month, and day. Y-M-D: Year/Month/Day M-D-Y: Month/Day/Year D-M-Y: Day/Month/Year

___ indicates the factory setting.

Setup menu list (continued)

DISPLAY SETUP screen (continued)

Item	Display mode	Description of settings
LEVEL METER	(Camera) (PB)	Select ON to display the audio level meter. ON, OFF
ZOOM & FOCUS	(Camera)	Selects the unit of zoom and focus values. OFF, NUMBER, mm/m, mm/feet <ul style="list-style-type: none"> Use the mm/feet or mm/m display only as a general guideline because it is not entirely accurate. When you are using a lens that has no communication connection between the camera and lens through the use of a mount adaptor, the zoom and focus values are not displayed.
CARD & BATTERY	(Camera) (PB)	Select ON to display the remaining SD Memory Card recording capacity and remaining battery charge. ON, OFF
OTHER DISPLAY	(Camera)	Select how much information to display on the viewfinder and LCD monitor. OFF, PARTIAL, ALL
LCD BACKLIGHT	(Camera) (PB)	Adjusts the backlight of the LCD monitor. +1, 0, - 1, - 2, - 3 +1: The backlight becomes brighter. - 3: The backlight becomes the darkest.
LCD SET	(Camera) (PB)	Adjusts the display level of images on the LCD monitor. BRIGHTNESS COLOR CONTRAST
EVF SET	(Camera) (PB)	Adjusts the display level of images on the viewfinder. BRIGHTNESS COLOR CONTRAST
SELF SHOOT	(Camera)	Selects the LCD mirror mode for self-portrait shooting. Selecting MIRROR displays the left and right side of the LCD monitor image inverted during self-portrait shooting. NORMAL, MIRROR
EVF MODE	(Camera) (PB)	Switches the screen display of images. AUTO: If you open the LCD monitor, images on the viewfinder disappear. ON: Images are always displayed on the viewfinder. <ul style="list-style-type: none"> When SDI OUT = ON, regardless of this item, AUTO settings are operated forcibly.
EVF COLOR	(Camera)	EVF COLOR (Camera) Switches viewfinder images to color or black and white. ON: Color OFF: Black and white

_____ indicates the factory setting.

CARD FUNCTIONS screen

Item	Display mode	Description of settings
CARD FORMAT	(Camera) (PB)	Formats the SD Memory Card. Slot1: Formats the SD Card inserted in Slot 1. Slot2: Formats the SD Card inserted in Slot 2. NO: Returns to the previous screen.
CARD STATUS	(Camera) (PB)	Displays the SD Memory Card status. Slot1: Displays the information about the SD Card inserted in Slot 1. Slot2: Displays the information about the SD Card inserted in Slot 2. NO: Returns to the previous screen.
CLIP PROPERTY	(PB)	Displays information about the selected clip. YES: Displays clip information. NO: Returns to the previous screen.

USER FILE screen

Item	Display mode	Description of settings
CARD READ	(Camera) (PB)	Reads the user files saved on the SD Memory Card. Slot1: Reads the user files from the SD Card inserted in Slot 1. Slot2: Reads the user files from the SD Card inserted in Slot 2. NO: Returns to the previous screen.
CARD WRITE	(Camera) (PB)	Saves the user files on the SD Memory Card. You can also add a title to the saved files. Slot1: Saves the user files on the SD Card inserted in Slot 1. Slot2: Saves the user files on the SD Card inserted in Slot 2. NO: Returns to the previous screen.
LOAD/SAVE/INIT	(Camera) (PB)	LOAD: Loads the settings in a previously stored user file. SAVE: Saves the updated user file settings. INIT: Returns the settings in the user file to factory settings. NO: Returns to the previous screen. <ul style="list-style-type: none"> • After a LOAD or INITIALIZE operation, turn OFF the POWER switch of the camera and then turn it ON again to make the new settings available. • The INITIALIZE operation does not change the TIME ZONE settings (Page 63).

___ indicates the factory setting.

Setup menu list (continued)

META DATA screen

Item	Display mode	Description of settings
CARD READ	(Camera)	Loads the metadata recorded on the SD Memory Card on to the unit. SLOT1, SLOT2, NO • "NO FILE" is displayed when no metadata is recorded on the SD Memory Card.
RECORD	(Camera)	Sets whether to record the metadata to be loaded on the unit simultaneously on a SD Memory Card. ON: Records simultaneously OFF: Does not record simultaneously
USER CLIP NAME	(Camera)	Selects the method of recording the USER CLIP NAME. TYPE1: The user clip name is the same as the CLIP NAME if no uploaded metadata or data exists. TYPE2: The user clip name is the same as the CLIP NAME if no combination of data and COUNT value is uploaded, or if no uploaded data exists.
META DATA PROP	(Camera)	Displays the metadata recorded in the unit. YES, NO
CLIP COUNTER RST	(Camera)	Resets the COUNT value to 1. YES, NO
META INT SET	(Camera)	Initializes the metadata recorded in the unit. All settings, including the ON or OFF setting for RECORD are now cleared. YES, NO

OTHER FUNCTIONS screen

Item	Display mode	Description of settings
LENS CHECK	(Camera)	ON: Checks the communication status with the lens. Video shooting is not performed if checking is not proper. OFF: Does not check the communication status with the lens. • It is recommended to set LENS CHECK to ON when you are using lenses conforming to the Micro Four Thirds and Four Thirds standard. • When you are using a lens that has no communication connection between the camera and lens through the use of a mount adaptor, video shooting is enabled when you set this item to OFF.
IR REMOTE	(Camera) (PB)	Sets the operations of the supplied remote control unit. ON: Accepts commands from the remote control. • Note that if the same type of remote control is used near the unit, the unit may receive commands from the other remote control, during shooting for example, and suddenly operate in an unexpected manner. OFF: Does not accept commands from the remote control.
TALLY LAMP	(Camera)	Sets lighting of the tally lamp. FRONT: The front tally lamp (microphone side) lights. REAR: The rear tally lamp (viewfinder side) lights. BOTH: Both tally lamps light. OFF: No tally lamp lights.
CLOCK SET	(Camera) (PB)	Sets the built-in calendar of the camera.

___ indicates the factory setting.

OTHER FUNCTIONS screen (continued)

Item	Display mode	Description of settings																																																																																																										
TIME ZONE	(Camera) (PB)	Adds to or deducts from GMT the time value of -12:00 to +13:00 in 30-minute steps. (Refer to the table below.) +00:00																																																																																																										
		<table border="1"> <thead> <tr> <th>Time difference</th> <th>Area</th> <th>Time difference</th> <th>Area</th> </tr> </thead> <tbody> <tr><td>+ 00:00</td><td>Greenwich</td><td>- 00:30</td><td></td></tr> <tr><td>- 01:00</td><td>Azores Islands</td><td>- 01:30</td><td></td></tr> <tr><td>- 02:00</td><td>Mid-Atlantic</td><td>- 02:30</td><td></td></tr> <tr><td>- 03:00</td><td>Buenos Aires</td><td>- 03:30</td><td>Newfoundland Island</td></tr> <tr><td>- 04:00</td><td>Halifax</td><td>- 04:30</td><td></td></tr> <tr><td>- 05:00</td><td>New York</td><td>- 05:30</td><td></td></tr> <tr><td>- 06:00</td><td>Chicago</td><td>- 06:30</td><td></td></tr> <tr><td>- 07:00</td><td>Denver</td><td>- 07:30</td><td></td></tr> <tr><td>- 08:00</td><td>Los Angeles</td><td>- 08:30</td><td></td></tr> <tr><td>- 09:00</td><td>Alaska</td><td>- 09:30</td><td>Marquesas Islands</td></tr> <tr><td>- 10:00</td><td>Hawaii</td><td>- 10:30</td><td></td></tr> <tr><td>- 11:00</td><td>Midway Island</td><td>- 11:30</td><td></td></tr> <tr><td>- 12:00</td><td>Kwajalein</td><td>+ 12:30</td><td></td></tr> <tr><td>+ 13:00</td><td></td><td>+ 11:30</td><td>Norfolk Island</td></tr> <tr><td>+ 12:00</td><td>New Zealand</td><td>+ 10:30</td><td>Lord Howe Island</td></tr> <tr><td>+ 11:00</td><td>Solomon Islands</td><td>+ 09:30</td><td>Darwin</td></tr> <tr><td>+ 10:00</td><td>Guam</td><td>+ 08:30</td><td></td></tr> <tr><td>+ 09:00</td><td>Tokyo</td><td>+ 07:30</td><td></td></tr> <tr><td>+ 08:00</td><td>Beijing</td><td>+ 06:30</td><td>Yangon</td></tr> <tr><td>+ 07:00</td><td>Bangkok</td><td>+ 05:30</td><td>Mumbai</td></tr> <tr><td>+ 06:00</td><td>Dacca</td><td>+ 04:30</td><td>Kabul</td></tr> <tr><td>+ 05:00</td><td>Islamabad</td><td>+ 03:30</td><td>Tehran</td></tr> <tr><td>+ 04:00</td><td>Abu Dhabi</td><td>+ 02:30</td><td></td></tr> <tr><td>+ 03:00</td><td>Moscow</td><td>+ 01:30</td><td></td></tr> <tr><td>+ 02:00</td><td>Eastern Europe</td><td>+ 00:30</td><td></td></tr> <tr><td>+ 01:00</td><td>Central Europe</td><td></td><td></td></tr> </tbody> </table>	Time difference	Area	Time difference	Area	+ 00:00	Greenwich	- 00:30		- 01:00	Azores Islands	- 01:30		- 02:00	Mid-Atlantic	- 02:30		- 03:00	Buenos Aires	- 03:30	Newfoundland Island	- 04:00	Halifax	- 04:30		- 05:00	New York	- 05:30		- 06:00	Chicago	- 06:30		- 07:00	Denver	- 07:30		- 08:00	Los Angeles	- 08:30		- 09:00	Alaska	- 09:30	Marquesas Islands	- 10:00	Hawaii	- 10:30		- 11:00	Midway Island	- 11:30		- 12:00	Kwajalein	+ 12:30		+ 13:00		+ 11:30	Norfolk Island	+ 12:00	New Zealand	+ 10:30	Lord Howe Island	+ 11:00	Solomon Islands	+ 09:30	Darwin	+ 10:00	Guam	+ 08:30		+ 09:00	Tokyo	+ 07:30		+ 08:00	Beijing	+ 06:30	Yangon	+ 07:00	Bangkok	+ 05:30	Mumbai	+ 06:00	Dacca	+ 04:30	Kabul	+ 05:00	Islamabad	+ 03:30	Tehran	+ 04:00	Abu Dhabi	+ 02:30		+ 03:00	Moscow	+ 01:30		+ 02:00	Eastern Europe	+ 00:30		+ 01:00	Central Europe
Time difference	Area	Time difference	Area																																																																																																									
+ 00:00	Greenwich	- 00:30																																																																																																										
- 01:00	Azores Islands	- 01:30																																																																																																										
- 02:00	Mid-Atlantic	- 02:30																																																																																																										
- 03:00	Buenos Aires	- 03:30	Newfoundland Island																																																																																																									
- 04:00	Halifax	- 04:30																																																																																																										
- 05:00	New York	- 05:30																																																																																																										
- 06:00	Chicago	- 06:30																																																																																																										
- 07:00	Denver	- 07:30																																																																																																										
- 08:00	Los Angeles	- 08:30																																																																																																										
- 09:00	Alaska	- 09:30	Marquesas Islands																																																																																																									
- 10:00	Hawaii	- 10:30																																																																																																										
- 11:00	Midway Island	- 11:30																																																																																																										
- 12:00	Kwajalein	+ 12:30																																																																																																										
+ 13:00		+ 11:30	Norfolk Island																																																																																																									
+ 12:00	New Zealand	+ 10:30	Lord Howe Island																																																																																																									
+ 11:00	Solomon Islands	+ 09:30	Darwin																																																																																																									
+ 10:00	Guam	+ 08:30																																																																																																										
+ 09:00	Tokyo	+ 07:30																																																																																																										
+ 08:00	Beijing	+ 06:30	Yangon																																																																																																									
+ 07:00	Bangkok	+ 05:30	Mumbai																																																																																																									
+ 06:00	Dacca	+ 04:30	Kabul																																																																																																									
+ 05:00	Islamabad	+ 03:30	Tehran																																																																																																									
+ 04:00	Abu Dhabi	+ 02:30																																																																																																										
+ 03:00	Moscow	+ 01:30																																																																																																										
+ 02:00	Eastern Europe	+ 00:30																																																																																																										
+ 01:00	Central Europe																																																																																																											
POWER SAVE	(Camera)	<p>Selects the power-saving mode when no operation is performed from the Operation lever, MENU button, AUDIO MON/ADV button, USER button, or START/STOP button for about five minutes when an SD Memory Card has been inserted in the CAM mode.</p> <p>ON: Power supply to the camera is turned OFF. OFF: Power supply to the camera is not turned OFF.</p> <ul style="list-style-type: none"> • Even when POWER SAVE has been set to ON, the power supply does not turn OFF when an SD Memory Card has not been inserted, when the camera-recorder is in the PB or PC mode, or when the AC adaptor is connected. 																																																																																																										
LANGUAGE	(Camera) (PB)	Sets the Menu language. ENGLISH, Deutsch, Français, Italiano, Español																																																																																																										
SYSTEM FREQ	(Camera) (PB)	Sets the system frequency 59.94Hz: NTSC region 50Hz: PAL region																																																																																																										
SYSTEM INFO	(Camera)	Displays the version of the system in this camera.																																																																																																										
LENS INFO	(Camera) (PB)	Displays the version of the Micro Four Thirds and Four Thirds lenses that have been installed.																																																																																																										
MENU INIT	(Camera)	Returns the menu settings (scene files and user files) to factory default settings. <ul style="list-style-type: none"> • The TIME ZONE settings do not return to factory default settings. 																																																																																																										

___ indicates the factory setting.

Setup menu list (continued)

OTHER FUNCTIONS screen (continued)

Item	Display mode	Description of settings
OPERATION TIME	(Camera) (PB)	Displays the power-on time (a 5-digit figure).
UPDATE	(Camera)	Updates the system. For details on the update information, see our home page http://pro-av.panasonic.net/ .
LENS UPDATE	(Camera)	Updates the lens firmware. For details about the update information, see the home page of each lens manufacturer.

___ indicates the factory setting.

PLAY SETUP screen

Item	Display mode	Description of settings
PB FORMAT	(PB)	Sets the playback format. When SYSTEM FREQ = 59.94 Hz 1080/60i (30P), 1080/24P, 720/60P(30P), 720/24P When SYSTEM FREQ = 50 Hz 1080/50i(25P), 720/50P(25P) • The REC FORMAT setting in the CAM mode prior to migrating to the PB mode becomes the default value of the PB FORMAT.
REPEAT PLAY	(PB)	ON, OFF When ON is selected, supported clips are played repeatedly.
RESUME PLAY	(PB)	ON, OFF When ON is selected, playback resumes from the video position where clip playback had stopped.
SKIP MODE	(PB)	Selects the starting position for cued playback after pausing. CLIP: Stops playback at the beginning of the previous clip. CLIP & INDEX: Stops at the beginning of the clip and the INDEX.

___ indicates the factory setting.

THUMBNAIL screen

Item	Display mode	Description of settings
THUMBNAIL MODE	(PB)	Selects the thumbnail display method. ALL: Displays all clips. SAME FORMAT: Displays clips in the same recording format. MARKER: Displays clips with shot marks. INDEX: Displays clips with an INDEX.
INDICATOR	(PB)	Sets whether or not to display the indicator. ON: Displays the indicator OFF: Does not display the indicator
DATA DISPLAY	(PB)	Selects the information to be displayed in the time display area of the clips. TC: Time code UB: User information TIME: Shooting time DATE: Shooting date DATE & TIME: Shooting date and time
DATE FORMAT	(PB)	Selects the order for displaying the recording date/time when DATA DISPLAY is set to either DATE or DATE & TIME. Y-M-D: Year/Month/Day M-D-Y: Month/Day/Year D-M-Y: Day/Month/Year

___ indicates the factory setting.

OPERATION screen

Item	Display mode	Description of settings
DELETE	(PB)	Deletes clips. ALL CLIPS: Deletes all clips. SELECT: Deletes only the selected clips. NO: Returns to the previous screen. • Clips for which CLIP PROTECT is specified are not deleted.
INDEX	(PB)	Adds an INDEX to a clip, or deletes the INDEX. YES: Displays the INDEX NO: Does not display the INDEX
CLIP PROTECT	(PB)	Protects clips to prevent accidental deletion. YES: Enables clip protection or cancels protection. NO: Returns to the previous screen. • Formatting the memory card will delete all clips even if they are protected.
COPY	(PB)	Copies clips (Page 36).

___ indicates the factory setting.

Before calling for service

Power supply

There's no power.	<ul style="list-style-type: none"> • Make sure the battery and AC adaptor are connected properly. Check the connections again. 	P E-25 of Vol.1
Power shuts off for no apparent reason.	<ul style="list-style-type: none"> • To prevent the battery from running down needlessly, the camera-recorder automatically turns off when the camera-recorder has been left in the recording pause mode for more than 5 minutes. Check the settings in the OTHER FUNCTIONS screen, POWER SAVE. 	P63
Power goes off as soon as it is turned on.	<ul style="list-style-type: none"> • The battery may have run out. If the remaining battery charge display is blinking or  appears, the battery has run out. Either recharge the battery or replace the discharged battery with a fully charged one. 	P E-24 of Vol.1

Battery

The battery runs down quickly.	<ul style="list-style-type: none"> • Make sure the battery is fully charged. Keep charging until the AC adaptor's CHARGE lamp goes out. • Are you using the battery in a cold place? The battery is affected by the ambient temperature. Its operating time is reduced in low-temperatures. • The battery may have reached the end of its service life. The battery will become unchargeable. The battery has a certain service life which varies depending on how the battery is used. If the battery operates only for a short period even when it is charged adequately, it has reached the end of its service life. 	P E-23 of Vol.1
The battery cannot be charged.	<ul style="list-style-type: none"> • The battery cannot be charged if the DC cord is connected. Disconnect it. 	P E-23 of Vol.1
The remaining battery capacity is not displayed correctly.	<ul style="list-style-type: none"> • The remaining battery capacity display is merely a guideline. To ensure that remaining battery capacity is displayed correctly, use the battery completely from a fully-charged state, and charge the battery again. (Remaining battery capacity may still not be displayed correctly if the battery has been used for long periods in high or low temperatures, or if the battery has been recharged a large number of times.) 	—

Shooting

Cannot start shooting.	<ul style="list-style-type: none"> • Make sure the POWER switch is ON. 	P E-27 of Vol.1
Cannot focus automatically.	<ul style="list-style-type: none"> • Make sure the camera is in manual focus mode. You can focus automatically when the auto focus mode is selected. • Auto focus is not available when using the VFR function. • Auto focus is not available at slow shutter speed settings. • Depending on the lens, the auto focus function may not be available. • You may be shooting a scene where it is difficult to bring the subject into focus in the auto focus mode. If this is the case, focus in the manual focus mode. <ul style="list-style-type: none"> It may be hard to bring the subject into focus when <ul style="list-style-type: none"> · both close and distant objects are to be shot · shooting through a dirty window · shooting in a dark place · there are sparkling or shiny objects around the subject · the subject is moving fast · shooting a scene with minimal contrast 	P E-39 of Vol.1

Recording

Cannot record even through the SD Memory Card is inserted correctly.	<ul style="list-style-type: none"> • Is the write-protect switch on the SD Memory Card in the "LOCK" position? The card cannot be recorded to if the switch is in the "LOCK" position. • Is the remaining memory available on the SD Memory Card extremely low? Please save contents onto different media and delete unneeded data from the card, or use a new card instead. • Has the SD Memory Card been correctly formatted? Alternatively, is the card of a format that is incompatible with this camera? Reformat the card with the camera. • 8 MB to 16 MB SD Memory Cards cannot be used for shooting movies. 	<p>P E-38 of Vol.1</p> <p>P E-36 of Vol.1</p> <p>P E-12 of Vol.1</p>
Recording stops by itself.	<ul style="list-style-type: none"> • Is your SD Memory Card compatible with use for video recording? Always use an SD Memory Card compatible with use for video recording. 	<p>P E-12 of Vol.1</p>

Editing

Cannot read the data on the SD Memory Card.	<ul style="list-style-type: none"> • Make sure the SD Memory Card is formatted correctly. If it is not, format the card in the unit. 	<p>P E-36 of Vol.1</p>
Cannot perform nonlinear editing.	<ul style="list-style-type: none"> • Check the specifications of your computer and connecting cable. 	<p>P42</p>
Cannot dub onto an external device.	<ul style="list-style-type: none"> • Make sure the external device is connected correctly. 	<p>P42</p>

Displays

Something is wrong with the time code display.	<ul style="list-style-type: none"> • The time code display may not register a regular count if a clip is played in the reverse slow mode. This is normal. 	<p>—</p>
---	--	----------

Playback

Cannot play even when I press the play button.	<ul style="list-style-type: none"> • Make sure the PB lamp is on (press the mode button). No kind of playback operation can be performed unless this lamp is on. 	<p>P28</p>
Mosaic-like noise appears when I cue or review a clip.	<ul style="list-style-type: none"> • This noise is inherent to digital video technology. This is normal. 	<p>—</p>
Images do not appear on the television even though I have connected the camera-recorder properly.	<ul style="list-style-type: none"> • Make sure the input selector on your television is set to video input. Read the television's instructions carefully and select the correct video input connector for the camera-recorder. 	<p>—</p>
Cannot hear any sound from the camera-recorder's speaker.	<ul style="list-style-type: none"> • You may have turned down the camera-recorder's volume control too far. Adjust the volume level using the AUDIO MON/ADV button +. 	<p>P40</p>

Before calling for service (continued)

PC connection

Computer does not recognize camera when USB connection cable is connected.	<ul style="list-style-type: none"> • Check the operating environment. • If your computer has multiple USB terminals, please try connecting the camera to a different USB terminal. • Switch the camera's power off and back on again, and reconnect the USB connection cable. 	P42
An error message appears on the computer when the USB connection cable is disconnected.	<ul style="list-style-type: none"> • To disconnect the USB connection cable safely, double-click the icon in the task tray, and follow the instructions on the screen. 	—

Other

The remote control does not work.	<ul style="list-style-type: none"> • The battery in the remote control may have run out. If the remote control fails to work even if it is operated close to the remote control sensor of the camera-recorder, it means that the battery has run out. Replace it with new one. • Is the IR REMOTE item on the setting menu OTHER FUNCTIONS screen set to OFF? 	P E-23 of Vol.1
There is a rattling sound when the camera-recorder is tilted back and forth.	<ul style="list-style-type: none"> • This is the sound of the lens moving. This is not a fault. No sound should be heard when the camera's power is switched on. 	—
A clicking sound is heard when the power is turned on or when the PB mode is switched to the CAM mode.	<ul style="list-style-type: none"> • This initialization operation is performed when the camera starts up. It occurs due to the construction of the camera and is not indicative of any trouble. 	—
The SD Memory Card screen appears strange.	<ul style="list-style-type: none"> • The data on the card could be corrupted. Data can be corrupted by static electricity and electromagnetic waves. Please always save important data to a computer or other storage media. 	—
The SD Memory Card cannot be used even after formatting.	<ul style="list-style-type: none"> • There could be a fault with the camera or with the SD Memory Card. Please consult the place of purchase. Always use only SD Memory Cards of 512 MB - 32 GB with this camera. 	—
The camera does not recognize the SD Memory Card even though it is inserted correctly.	<ul style="list-style-type: none"> • Was the inserted SD Memory Card originally formatted with a computer? Always use this camera to format SD Memory Cards. Please be aware that, when an SD Memory Card is formatted, all data recorded on the card will be erased and will not be restorable. 	P E-36 of Vol.1
The SD Memory Card is not recognized when inserted into other devices.	<ul style="list-style-type: none"> • Please check that the device is compatible with the capacity or type (SD Memory Card/SDHC Memory Card/SDXC Memory Card) of the SD Memory Card that you are using. For details, please consult the device's own operating instructions. 	P E-12 of Vol.1

The changeover between clips may not always be smooth when playing back multiple clips in succession. Video may momentarily pause when playing back multiple clips in succession in circumstances such as those detailed below.

■ **Mixture of different recording formats**

Recording mode = PH mode
 Playback format = 1080/50i(25P)

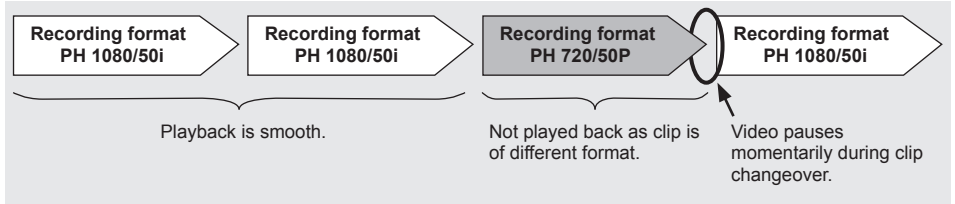

■ **Mixture of different recording modes**

Recording format = 1080/50i
 Playback format = 1080/50i(25P)

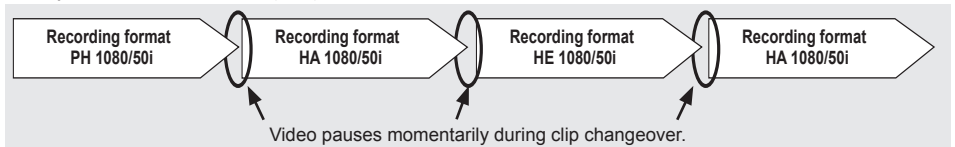

■ **Some clips have been recorded using PRE REC function or VFR function**

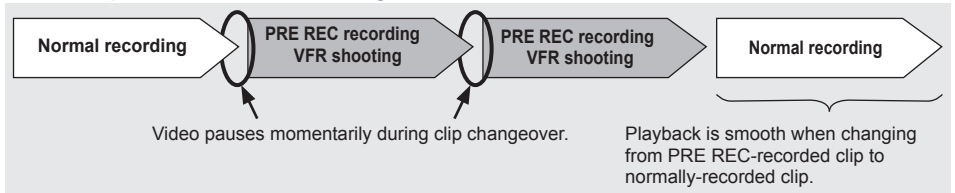

■ **Some clips have a recording time of less than 3 seconds**

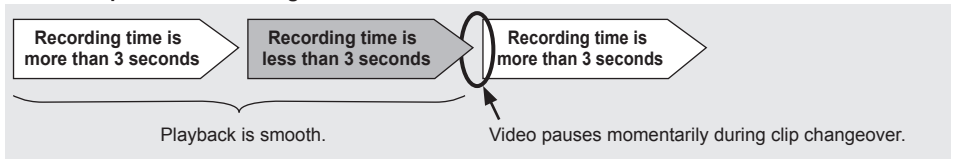

Updating the firmware incorporated into the unit

The firmware can be updated using either of the following two methods.

1 Checking the current version of firmware and performing the update using the dedicated tool (P2_Status_Logger)

PASS (P2 Asset Support System) is only available to customers who have completed customer registration with Panasonic.

Log in to PASS and use the dedicated tool (P2_Status_Logger) to check the version information of the firmware on the unit and download links to pages containing the necessary firmware.

For further information about downloading and using P2_Status_Logger, log in to PASS and refer to the relevant pages.

Besides access to PASS, completing customer registration has a number of other benefits. For further details, refer to the PASS (P2 Asset Support System) website (http://panasonic.biz/sav/pass_e/).

2 Checking the current version of the firmware using the unit and performing the update

From the OTHER FUNCTIONS menu page, check the current version of firmware on the unit using the SYSTEM INFO screen. Then, access the website listed below for the latest firmware-related information and download firmware as required.

- The update is completed by loading the downloaded file onto the unit via an SD memory card. For further details about the updating methods, refer to the following website.
<http://pro-av.panasonic.net/>
 - Be sure to use a compatible SD memory card. The unit is compatible with SD memory cards based on the SD, SDHC and SDXC standards. Also, be sure to format the memory card using the unit before use.
-

Cleaning

When cleaning, do not use benzene or thinner.

- Using benzene or paint thinners may deform the camera-recorder and/or cause the surface finish to peel off.
- Before proceeding with maintenance, remove the battery or disconnect the AC cord from the power outlet.
- Use a soft, clean cloth to wipe the camera-recorder. To remove stubborn dirt, wipe the camera-recorder with a cloth moistened with kitchen detergent that has been diluted with water and then use a dry cloth to take up the remaining moisture.

Cleaning the Viewfinder

If there is dust inside the viewfinder, remove the eye cup holder and get rid of the dust.

- The interior of the eye cup holder is specially finished, so do not ever wipe it. If there is dust on it, blow it off with an air blower.
- Remove the eye cup holder with the eye cup attached by rotating it counterclockwise. (It will be tightly screwed on.) When you do this, tilt the viewfinder slightly upward.
- To mount the eye cup holder, align the ridges and grooves of the eye cup holder and camera-recorder, and turn clockwise until the holder clicks into place.

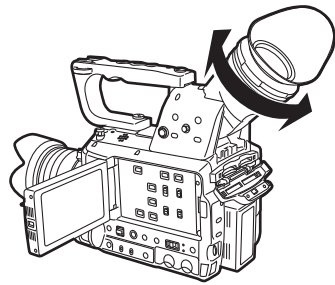
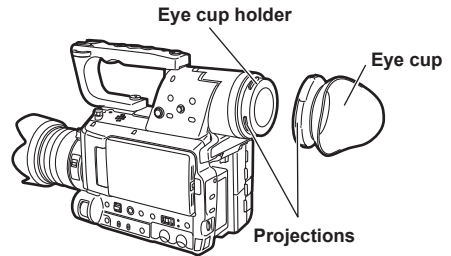

Storage Precautions

Before storing the camera-recorder, remove both the SD Memory Card and battery.

Store all of these items in a place with low humidity and relatively constant temperature.

[Recommended temperature range: 15°C to 25°C]

[Recommended relative humidity: 40% to 60%]

Camera-recorder

- Wrap the camera-recorder in a soft cloth to keep the dust off.

Battery

- The battery life is shortened in places with extreme temperatures.
- Storing the battery in a location with oily vapors or high dust concentrations may corrode the terminals or cause other damage, leading to malfunction.
- **Keep metal objects (such as necklaces and hairpins) away from the terminals. Short-circuiting may occur across the terminals, causing the battery to heat up, and you may seriously burn yourself if you touch the battery in this state.**

SD Memory Cards

- After ejecting an SD Memory Card from the unit, be absolutely sure to stow it in its own case.
- Do not leave SD Memory Cards in areas where corrosive gases, etc. are present.
- Do not leave the cards inside vehicles, in places exposed to direct sunlight or in other places where the temperature is high.
- Do not leave the cards where the humidity level is high or where there are high concentrations of dust.

How to handle data recorded on SD Memory Card

Data recorded in AVCHD format offers excellent compatibility with computers due to the file type, but since this format includes not only video and audio data, but also a variety of important information, the folder structure will consist of file associations as illustrated in the diagram on the right. If even part of this information is modified or deleted, the data may no longer be recognized as AVCHD data, or the memory card may not longer be able to be used with AVCHD devices.

To prevent the loss of any part of the information when transferring data on the SD Memory Card to a computer or when copying data stored on a

computer back onto the SD Memory Card, be sure to use the dedicated AVCCAM Viewer.

The AVCCAM Viewer can also be downloaded from the following website.

(Compatible OS: Windows XP/Windows Vista/Windows 7 or Mac OS 10.4 or later/Mac OS 10.5/Mac OS 10.6)

<http://pro-av.panasonic.net/>

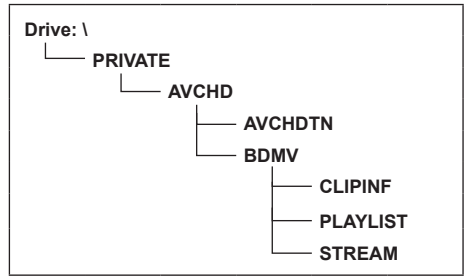

■ Concerning the handling of the camera's metadata

A special manufacturer area in the control file area under the AVCHD standard is employed for the metadata which is supported by this camera.

If files are deleted or copied, if clip protection is added or removed or if other such editing operations have been performed using editing software or a camera recorder which does not support this camera's metadata, the special area for the metadata will be erased, and the shot marks and indexes added by the camera as well as the PH mode information and other information will be lost. Therefore, before proceeding with these kinds of editing operations, check whether the camera's metadata is supported.

Panasonic Corporation

Web Site: <http://panasonic.net>

© Panasonic Corporation 2010

